



# PACKAGE GAS ELECTRIC UNITS

FORM NO. RTZ-839

Featuring Earth-Friendly R-410A Refrigerant



**TZGE-3\*\*JL 13-SEER SERIES**  
 NOMINAL SIZES 2-5 TONS [7.0-17.6 kW]

**TZGE-4\*\*JL 14-SEER SERIES**  
 NOMINAL SIZES 2-5 TONS [7.0-17.6 kW]



Manufactured for  
**Thermal Zone®**  
 Philadelphia, PA



ENERGUIDE		
Seasonal Energy Efficiency Ratio (SEER)		
BRNL 13.0	BRPL 14.0	BRRL 16.0
10.6 — Uses least energy → 16.05		
Annual Fuel Utilization Efficiency - AFUE		
THIS MODEL		
80.0%		
MID	HIGH	
78%	82%	88% 97%



# TABLE OF CONTENTS



Unit Features & Benefits .....	3-4
Model Identification Options .....	5
General Data	
TZGE-3 Series .....	6-9
TZGE-4 Series .....	10-13
General Data Notes.....	14
Performance Data	
TZGE-3 Series .....	15-17
TZGE-4 Series .....	18-20
Airflow Performance	
TZGE-3 Series .....	21-23
TZGE-4 Series .....	24-27
Electrical Data	
TZGE-3 Series .....	28-29
TZGE-4 Series .....	30-31
Dimensional Data .....	32-33
Typical Installations .....	34
Accessories .....	35-42
Wiring Diagram/Schematic .....	43-48
Limited Warranty .....	52

***These quality features are included in the Thermal Zone® Gas Heat/Electric Cooling Package Unit***

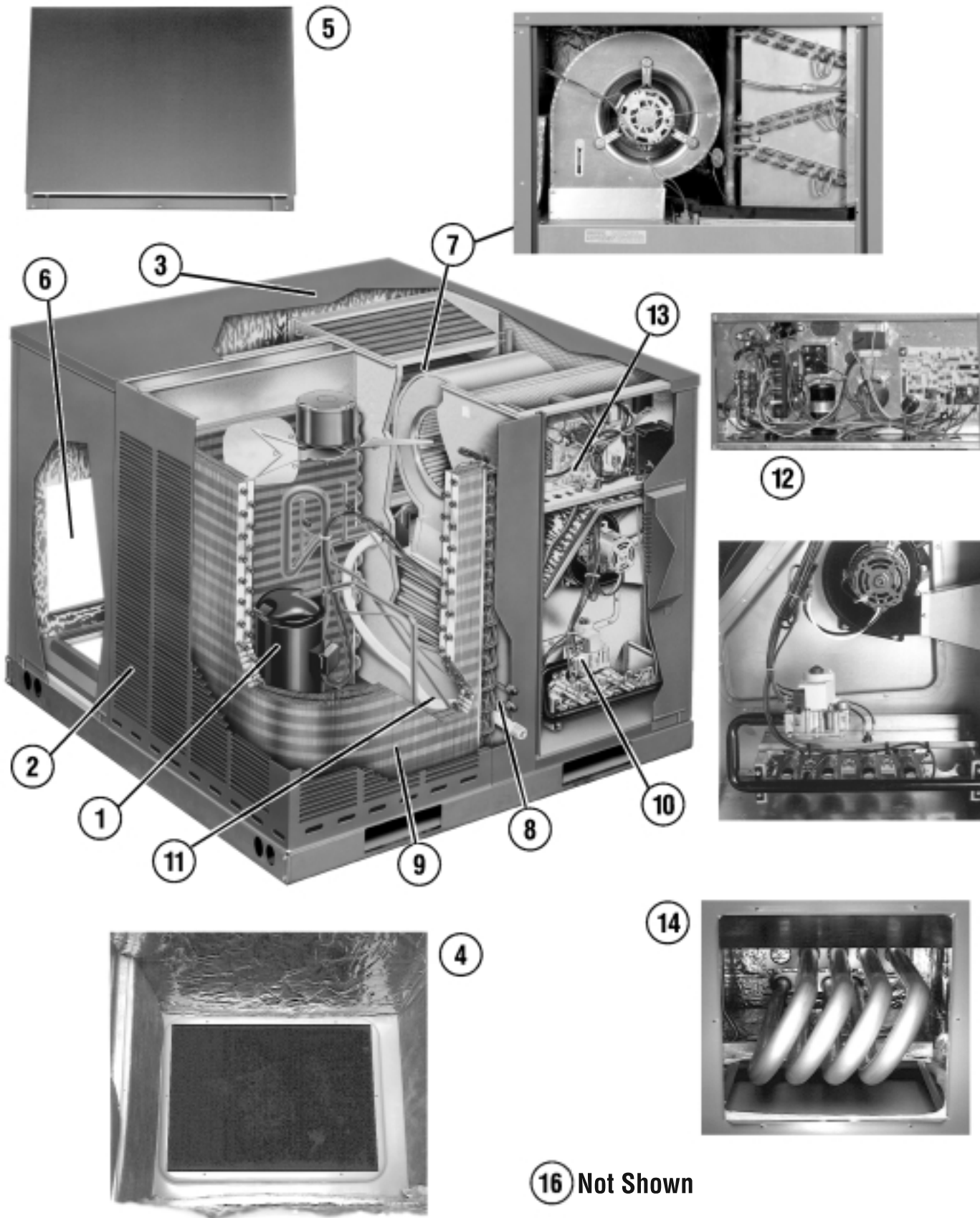

## UNIT FEATURES & BENEFITS—TZGE-3/TZGE-4 SERIES



### Features Below Correspond to Photos on Page 3

1. All models feature Scroll® compressors for maximum efficiency and quiet operation. 5 Ton TZGE-3/TZGE-4 feature UltraTech™ Scroll 2-Stage compressors with Comfort Alert™ diagnostics (see below), high/low pressure switches, and hard start kits.
2. Louvered condenser compartment for protecting the coil against yard hazards and/or weather extremes.
3. One-piece top with a deep flange to help keep water out of the unit.
4. Supply and return air openings feature a one-inch tall flange to prevent water migration into the ductwork.
5. Access panels have “weep holes” and channels to further help manage water run-off.
6. Side and down discharge conversion available on all models.
7. Easily accessible blower section complete with slide-out blower.
8. Refrigerant connections are conveniently located for easy service diagnostics.
9. Condenser and evaporator coils feature enhanced fins for better heat transfer and rifled copper tubing for greater efficiency.
10. Inside the easily accessible furnace compartment is the draft inducer motor. This motor is specially designed for quiet reliable operation. In addition to the draft inducer motor, the in-shot gas burners and manifold efficiently regulate the flow of gas for combustion. These new gas/electric units also feature direct-spark ignition and remote flame sensors for added reliability and efficiency.
11. All units feature an internal trap on the condensate line eliminating the need for installing an on-site external trap.
12. Easily accessible control box.
13. Single point wiring simplifies installation.
14. Our gas/electric package units feature a tubular heat exchanger design. Tubular heat exchangers are more efficient and durable than older-style clamshell heat exchangers. The heat exchanger is backed by a 10 year limited warranty. Models with a stainless steel heat exchanger installed in a residential application are backed by a limited lifetime warranty.
15. Thermal expansion valve standard on all models for superior superheat control, reliability, and energy efficiency at all operating conditions.
16. Filter drier standard on all models (not shown).
17. Rugged baserail included for improved installation and handling.

# MODEL IDENTIFICATION—TZGE-3/TZGE-4 SERIES



<u>TZ</u>	<u>GE</u>	<u>— 3</u>	<u>24</u>	<u>J</u>	<u>L</u>	<u>040</u>	<u>A</u>
THERMAL ZONE*	GAS/ELECTRIC	3 = 13 SEER 4 = 14 SEER	COOLING CAPACITY (BTUH) [Kw]	ELECTRICAL DESIGNATION	DESIGN SERIES	HEATING CAPACITY (MBH)	A = STANDARD (SIDEFLOW) AS = STAINLESS STEEL HEAT EXCHANGER/SIDEFLOW AX = LOW NO <sub>x</sub>
			024 = 24,000 [7.03 kW] 030 = 30,000 [8.79 kW] 036 = 36,000 [10.55 kW] 042 = 42,000 [12.31 kW] 048 = 48,000 [14.07 kW] 060 = 60,000 [17.58 kW]	J = 208-230V —1PH—60Hz C = 208-230V —3PH—60Hz D = 460V—3PH—60Hz	L = R-410A REFRIGERANT	040 = 40,000 [11.7] 060 = 60,000 [17.6] 080 = 80,000 [23.4] 100 = 100,000 [29.3]	

# GENERAL DATA—TZGE-3 SERIES

## NOMINAL SIZES 2-5 TONS [7.0-17.6 kW]

Model TZGE- Series	324JL040	324JL060	324JL080	330JL060
<b>Cooling Performance<sup>1</sup></b>				<b>CONTINUED</b> →
Gross Cooling Capacity Btu [kW]	24,400 [7.15]	24,400 [7.15]	24,400 [7.15]	29,800 [8.73]
EER/SEER <sup>2</sup>	11.1/13	11.1/13	11.1/13	11.1/13
Nominal CFM/ARI Rated CFM [L/s]	787/800 [371/378]	787/800 [371/378]	787/800 [371/378]	953/1000 [450/472]
ARI Net Cooling Capacity Btu [kW]	23,600 [6.91]	23,600 [6.91]	23,600 [6.91]	28,600 [8.38]
Net Sensible Capacity Btu [kW]	17,340 [5.08]	17,340 [5.08]	17,340 [5.08]	20,810 [6.1]
Net Latent Capacity Btu [kW]	6,260 [1.83]	6,260 [1.83]	6,260 [1.83]	7,790 [2.28]
Net System Power kW	2.12	2.12	2.12	2.58
<b>Heating Performance (Package Gas/Electric)<sup>3</sup></b>				
Heating Input Btu [kW]	40,000 [11.72]	60,000 [17.58]	80,000 [23.44]	60,000 [17.58]
Heating Output Btu [kW]	31,000 [9.08]	47,000 [13.77]	62,000 [18.17]	47,000 [13.77]
Temperature Rise Range °F [°C]	30-60 [16.7/33.3]	40-70 [22.2/38.9]	55-85 [30.6/47.2]	30-60 [16.7/33.3]
AFUE (%) <sup>4</sup>	80	80	80	80
Steady State Efficiency (%)	81	81	81	81
No. Burners	2	3	4	3
No. Stages	1	1	1	1
Gas Connection Pipe Size in. [mm]	0.5 [12.7]	0.5 [12.7]	0.5 [12.7]	0.5 [12.7]
<b>Compressor</b>				
No./Type	1/Scroll	1/Scroll	1/Scroll	1/Scroll
<b>Outdoor Sound Rating (dB)<sup>5</sup></b>	76	76	76	76
<b>Outdoor Coil—Fin Type</b>	Louvered	Louvered	Louvered	Louvered
Tube Type	Rifled	Rifled	Rifled	Rifled
Tube Size in. [mm] OD	0.375 [9.5]	0.375 [9.5]	0.375 [9.5]	0.375 [9.5]
Face Area sq. ft. [sq. m]	10.56 [0.98]	10.56 [0.98]	10.56 [0.98]	10.56 [0.98]
Rows / FPI [FPcm]	1 / 18 [7]	1 / 18 [7]	1 / 18 [7]	1 / 18 [7]
<b>Indoor Coil—Fin Type</b>	Louvered	Louvered	Louvered	Louvered
Tube Type	Rifled	Rifled	Rifled	Rifled
Tube Size in. [mm]	0.375 [9.5]	0.375 [9.5]	0.375 [9.5]	0.375 [9.5]
Face Area sq. ft. [sq. m]	5.54 [0.51]	5.54 [0.51]	5.54 [0.51]	5.54 [0.51]
Rows / FPI [FPcm]	2 / 15 [6]	2 / 15 [6]	2 / 15 [6]	2 / 15 [6]
Refrigerant Control	TX Valves	TX Valves	TX Valves	TX Valves
Drain Connection No./Size in. [mm]	1/0.75 [19.05]	1/0.75 [19.05]	1/0.75 [19.05]	1/0.75 [19.05]
<b>Outdoor Fan—Type</b>	Propeller	Propeller	Propeller	Propeller
No. Used/Diameter in. [mm]	1/22 [558.8]	1/22 [558.8]	1/22 [558.8]	1/22 [558.8]
Drive Type/No. Speeds	Direct/1	Direct/1	Direct/1	Direct/1
CFM [L/s]	2500 [1180]	2500 [1180]	2500 [1180]	2500 [1180]
No. Motors/HP	1 at 1/3 HP	1 at 1/3 HP	1 at 1/3 HP	1 at 1/3 HP
Motor RPM	1075	1075	1075	1075
<b>Indoor Fan—Type</b>	FC Centrifugal	FC Centrifugal	FC Centrifugal	FC Centrifugal
No. Used/Diameter in. [mm]	1/9x7 [229x178]	1/9x7 [229x178]	1/9x7 [229x178]	1/10x9 [254x229]
Drive Type/No. Speeds	Direct/2	Direct/2	Direct/2	Direct/3
No. Motors	1	1	1	1
Motor HP	1/4	1/4	1/4	1/2
Motor RPM	1075	1075	1075	1075
Motor Frame Size	48	48	48	48
<b>Filter—Type</b>	Field Supplied	Field Supplied	Field Supplied	Field Supplied
Furnished	No	No	No	No
(No.) Size Recommended in. [mm]	(1)1x20x20 [25x508x508]	(1)1x20x20 [25x508x508]	(1)1x20x20 [25x508x508]	(1)1x24x24 [25x610x610]
<b>Refrigerant Charge Oz. [g]</b>	77.8 [2206]	77.8 [2206]	77.8 [2206]	76.8 [2177]
<b>Weights</b>				
Net Weight lbs. [kg]	381 [173]	385 [175]	390 [177]	404 [183]
Ship Weight lbs. [kg]	421 [191]	425 [193]	430 [195]	444 [201]

See Page 14 for Notes.

[ ] Designates Metric Conversions

## NOMINAL SIZES 2-5 TONS [7.0-17.6 kW]

Model TZGE- Series	330JL080	330JL100	336CL080	336CL100
<b>Cooling Performance<sup>1</sup></b>				<b>CONTINUED</b> →
Gross Cooling Capacity Btu [kW]	29,800 [8.73]	29,800 [8.73]	37,000 [10.84]	37,000 [10.84]
EER/SEER <sup>2</sup>	11.1/13	11.1/13	11.3/13	11.3/13
Nominal CFM/ARI Rated CFM [L/s]	953/1000 [450/472]	953/1000 [450/472]	1187/1200 [560/566]	1187/1200 [560/566]
ARI Net Cooling Capacity Btu [kW]	28,600 [8.38]	28,600 [8.38]	35,600 [10.43]	35,600 [10.43]
Net Sensible Capacity Btu [kW]	20,810 [6.1]	20,810 [6.1]	26,390 [7.73]	26,390 [7.73]
Net Latent Capacity Btu [kW]	7,790 [2.28]	7,790 [2.28]	9,210 [2.7]	9,210 [2.7]
Net System Power kW	2.58	2.58	3.15	3.15
<b>Heating Performance (Package Gas/Electric)<sup>3</sup></b>				
Heating Input Btu [kW]	80,000 [23.44]	100,000 [29.3]	80,000 [23.44]	100,000 [29.3]
Heating Output Btu [kW]	62,000 [18.17]	77,000 [22.56]	64,800 [18.99]	81,000 [23.73]
Temperature Rise Range °F [°C]	40-70 [22.2/38.9]	45-85 [25/47.2]	40-70 [22.2/38.9]	45-85 [25/47.2]
AFUE (%) <sup>4</sup>	80	80	80	80
Steady State Efficiency (%)	81	81	81	81
No. Burners	4	5	4	5
No. Stages	1	1	1	1
Gas Connection Pipe Size in. [mm]	0.5 [12.7]	0.5 [12.7]	0.5 [12.7]	0.5 [12.7]
<b>Compressor</b>				
No./Type	1/Scroll	1/Scroll	1/Scroll	1/Scroll
<b>Outdoor Sound Rating (dB)<sup>5</sup></b>	76	76	76	76
<b>Outdoor Coil—Fin Type</b>	Louvered	Louvered	Louvered	Louvered
Tube Type	Rifled	Rifled	Rifled	Rifled
Tube Size in. [mm] OD	0.375 [9.5]	0.375 [9.5]	0.375 [9.5]	0.375 [9.5]
Face Area sq. ft. [sq. m]	10.56 [0.98]	10.56 [0.98]	14.8 [1.37]	14.8 [1.37]
Rows / FPI [FPcm]	1 / 18 [7]	1 / 18 [7]	1 / 22 [9]	1 / 22 [9]
<b>Indoor Coil—Fin Type</b>	Louvered	Louvered	Louvered	Louvered
Tube Type	Rifled	Rifled	Rifled	Rifled
Tube Size in. [mm]	0.375 [9.5]	0.375 [9.5]	0.375 [9.5]	0.375 [9.5]
Face Area sq. ft. [sq. m]	5.54 [0.51]	5.54 [0.51]	5.54 [0.51]	5.54 [0.51]
Rows / FPI [FPcm]	2 / 15 [6]	2 / 15 [6]	2 / 15 [6]	2 / 15 [6]
Refrigerant Control	TX Valves	TX Valves	TX Valves	TX Valves
Drain Connection No./Size in. [mm]	1/0.75 [19.05]	1/0.75 [19.05]	1/0.75 [19.05]	1/0.75 [19.05]
<b>Outdoor Fan—Type</b>	Propeller	Propeller	Propeller	Propeller
No. Used/Diameter in. [mm]	1/22 [558.8]	1/22 [558.8]	1/22 [558.8]	1/22 [558.8]
Drive Type/No. Speeds	Direct/1	Direct/1	Direct/1	Direct/1
CFM [L/s]	2500 [1180]	2500 [1180]	2700 [1274]	2700 [1274]
No. Motors/HP	1 at 1/3 HP	1 at 1/3 HP	1 at 1/3 HP	1 at 1/3 HP
Motor RPM	1075	1075	1075	1075
<b>Indoor Fan—Type</b>	FC Centrifugal	FC Centrifugal	FC Centrifugal	FC Centrifugal
No. Used/Diameter in. [mm]	1/10x9 [254x229]	1/10x9 [254x229]	1/10x9 [254x229]	1/10x9 [254x229]
Drive Type/No. Speeds	Direct/3	Direct/3	Direct/3	Direct/3
No. Motors	1	1	1	1
Motor HP	1/2	1/2	1/2	1/2
Motor RPM	1075	1075	1075	1075
Motor Frame Size	48	48	48	48
<b>Filter—Type</b>	Field Supplied	Field Supplied	Field Supplied	Field Supplied
Furnished	No	No	No	No
(No.) Size Recommended in. [mm]	(1)1x24x24 [25x610x610]	(1)1x24x24 [25x610x610]	(1)1x24x24 [25x610x610]	(1)1x24x24 [25x610x610]
<b>Refrigerant Charge Oz. [g]</b>	76.8 [2177]	76.8 [2177]	92.8 [2631]	92.8 [2631]
<b>Weights</b>				
Net Weight lbs. [kg]	409 [186]	414 [188]	422 [191]	426 [193]
Ship Weight lbs. [kg]	449 [204]	454 [206]	462 [210]	466 [211]

See Page 14 for Notes.

[ ] Designates Metric Conversions



# GENERAL DATA—TZGE-3 SERIES

## NOMINAL SIZES 2-5 TONS [7.0-17.6 kW]

Model TZGE- Series	330JL080	336JL100	342CL100	342JL100
<b>Cooling Performance<sup>1</sup></b>				<b>CONTINUED</b> →
Gross Cooling Capacity Btu [kW]	37,000 [10.84]	37,000 [10.84]	44,000 [12.89]	44,000 [12.89]
EER/SEER <sup>2</sup>	11.3/13	11.3/13	11.2/13	11.2/13
Nominal CFM/ARI Rated CFM [L/s]	1187/1200 [560/566]	1187/1200 [560/566]	1400/1400 [661/661]	1400/1400 [661/661]
ARI Net Cooling Capacity Btu [kW]	35,600 [10.43]	35,600 [10.43]	42,000 [12.31]	42,000 [12.31]
Net Sensible Capacity Btu [kW]	26,390 [7.73]	26,390 [7.73]	30,510 [8.94]	30,510 [8.94]
Net Latent Capacity Btu [kW]	9,210 [2.7]	9,210 [2.7]	11,490 [3.37]	11,490 [3.37]
Net System Power kW	3.15	3.15	3.73	3.73
<b>Heating Performance (Package Gas/Electric)<sup>3</sup></b>				
Heating Input Btu [kW]	80,000 [23.44]	100,000 [29.3]	100,000 [29.3]	100,000 [29.3]
Heating Output Btu [kW]	62,000 [18.17]	77,000 [22.56]	81,000 [23.73]	77,000 [22.56]
Temperature Rise Range °F [°C]	40-70 [22.2/38.9]	45-85 [25/47.2]	45-85 [25/47.2]	45-85 [25/47.2]
AFUE (%) <sup>4</sup>	80	80	80	80
Steady State Efficiency (%)	81	81	81	81
No. Burners	4	5	5	5
No. Stages	1	1	1	1
Gas Connection Pipe Size in. [mm]	0.5 [12.7]	0.5 [12.7]	0.5 [12.7]	0.5 [12.7]
<b>Compressor</b>				
No./Type	1/Scroll	1/Scroll	1/Scroll	1/Scroll
<b>Outdoor Sound Rating (dB)<sup>5</sup></b>	76	76	76	76
<b>Outdoor Coil—Fin Type</b>	Louvered	Louvered	Louvered	Louvered
Tube Type	Rifled	Rifled	Rifled	Rifled
Tube Size in. [mm] OD	0.375 [9.5]	0.375 [9.5]	0.375 [9.5]	0.375 [9.5]
Face Area sq. ft. [sq. m]	14.8 [1.37]	14.8 [1.37]	16.65 [1.55]	16.65 [1.55]
Rows / FPI [FPcm]	1 / 22 [9]	1 / 22 [9]	1 / 22 [9]	1 / 22 [9]
<b>Indoor Coil—Fin Type</b>	Louvered	Louvered	Louvered	Louvered
Tube Type	Rifled	Rifled	Rifled	Rifled
Tube Size in. [mm]	0.375 [9.5]	0.375 [9.5]	0.375 [9.5]	0.375 [9.5]
Face Area sq. ft. [sq. m]	5.54 [0.51]	5.54 [0.51]	7.39 [0.69]	7.39 [0.69]
Rows / FPI [FPcm]	2 / 15 [6]	2 / 15 [6]	2 / 15 [6]	2 / 15 [6]
Refrigerant Control	TX Valves	TX Valves	TX Valves	TX Valves
Drain Connection No./Size in. [mm]	1/0.75 [19.05]	1/0.75 [19.05]	1/0.75 [19.05]	1/0.75 [19.05]
<b>Outdoor Fan—Type</b>	Propeller	Propeller	Propeller	Propeller
No. Used/Diameter in. [mm]	1/22 [558.8]	1/22 [558.8]	1/22 [558.8]	1/22 [558.8]
Drive Type/No. Speeds	Direct/1	Direct/1	Direct/1	Direct/1
CFM [L/s]	2700 [1274]	2700 [1274]	3500 [1652]	3500 [1652]
No. Motors/HP	1 at 1/3 HP	1 at 1/3 HP	1 at 1/3 HP	1 at 1/3 HP
Motor RPM	1075	1075	1075	1075
<b>Indoor Fan—Type</b>	FC Centrifugal	FC Centrifugal	FC Centrifugal	FC Centrifugal
No. Used/Diameter in. [mm]	1/10x9 [254x229]	1/10x9 [254x229]	1/10x9 [254x229]	1/10x9 [254x229]
Drive Type/No. Speeds	Direct/3	Direct/3	Direct/3	Direct/3
No. Motors	1	1	1	1
Motor HP	1/2	1/2	1/2	1/2
Motor RPM	1075	1075	1075	1075
Motor Frame Size	48	48	48	48
<b>Filter—Type</b>	Field Supplied	Field Supplied	Field Supplied	Field Supplied
Furnished	No	No	No	No
(No.) Size Recommended in. [mm]	(1)1x24x24 [25x610x610]	(1)1x24x24 [25x610x610]	(1)1x24x24 [25x610x610]	(1)1x24x24 [25x610x610]
<b>Refrigerant Charge Oz. [g]</b>	92.8 [2631]	92.8 [2631]	112 [3175]	112 [3175]
<b>Weights</b>				
Net Weight lbs. [kg]	422 [191]	426 [193]	437 [198]	437 [198]
Ship Weight lbs. [kg]	462 [210]	466 [211]	477 [216]	477 [216]

See Page 14 for Notes.

[ ] Designates Metric Conversions



## NOMINAL SIZES 2-5 TONS [7.0-17.6 kW]

Model TZGE- Series	348CL100	348JL100	360CL100	360JL100
<b>Cooling Performance<sup>1</sup></b>				<b>CONTINUED</b> →
Gross Cooling Capacity Btu [kW]	50,000 [14.65]	50,000 [14.65]	59,500 [17.43]	59,500 [17.43]
EER/SEER <sup>2</sup>	11.2/13	11.2/13	10.5/13	10.5/13
Nominal CFM/ARI Rated CFM [L/s]	1600/1600 [755/755]	1600/1600 [755/755]	2000/1850 [944/873]	1900/1850 [897/873]
ARI Net Cooling Capacity Btu [kW]	48,000 [14.06]	48,000 [14.06]	57,500 [16.85]	57,500 [16.85]
Net Sensible Capacity Btu [kW]	33,990 [9.96]	33,990 [9.96]	40,460 [11.85]	40,460 [11.85]
Net Latent Capacity Btu [kW]	14,010 [4.1]	14,010 [4.1]	17,040 [4.99]	17,040 [4.99]
Net System Power kW	4.28	4.28	5.48	5.48
<b>Heating Performance (Gas)<sup>3</sup></b>				
Heating Input Btu [kW]	100,000 [29.3]	100,000 [29.3]	100,000 [29.3]	100,000 [29.3]
Heating Output Btu [kW]	81,000 [23.73]	77,000 [22.56]	81,000 [23.73]	77,000 [22.56]
Temperature Rise Range °F [°C]	45-85 [25/47.2]	45-85 [25/47.2]	45-85 [25/47.2]	45-85 [25/47.2]
AFUE (%) <sup>4</sup>	80	80	80	80
Steady State Efficiency (%)	81	81	81	81
No. Burners	5	5	5	5
No. Stages	1	1	1	1
Gas Connection Pipe Size in. [mm]	0.5 [12.7]	0.5 [12.7]	0.5 [12.7]	0.5 [12.7]
<b>Compressor</b>				
No./Type	1/Scroll	1/Scroll	1/Scroll	1/Scroll
<b>Outdoor Sound Rating (dB)<sup>5</sup></b>	78	78	78	78
<b>Outdoor Coil—Fin Type</b>	Louvered	Louvered	Louvered	Louvered
Tube Type	Rifled	Rifled	Rifled	Rifled
Tube Size in. [mm] OD	0.375 [9.5]	0.375 [9.5]	0.375 [9.5]	0.375 [9.5]
Face Area sq. ft. [sq. m]	16.23 [1.51]	16.23 [1.51]	16.23 [1.51]	16.23 [1.51]
Rows / FPI [FPcm]	2 / 22 [9]	2 / 22 [9]	2 / 22 [9]	2 / 22 [9]
<b>Indoor Coil—Fin Type</b>	Louvered	Louvered	Louvered	Louvered
Tube Type	Rifled	Rifled	Rifled	Rifled
Tube Size in. [mm]	0.375 [9.5]	0.375 [9.5]	0.375 [9.5]	0.375 [9.5]
Face Area sq. ft. [sq. m]	7.39 [0.69]	7.39 [0.69]	7.39 [0.69]	7.39 [0.69]
Rows / FPI [FPcm]	2 / 15 [6]	2 / 15 [6]	2 / 15 [6]	2 / 15 [6]
Refrigerant Control	TX Valves	TX Valves	TX Valves	TX Valves
Drain Connection No./Size in. [mm]	1/0.75 [19.05]	1/0.75 [19.05]	1/0.75 [19.05]	1/0.75 [19.05]
<b>Outdoor Fan—Type</b>	Propeller	Propeller	Propeller	Propeller
No. Used/Diameter in. [mm]	1/22 [558.8]	1/22 [558.8]	1/22 [558.8]	1/22 [558.8]
Drive Type/No. Speeds	Direct/1	Direct/1	Direct/1	Direct/1
CFM [L/s]	3300 [1557]	3300 [1557]	3300 [1557]	3300 [1557]
No. Motors/HP	1 at 1/3 HP	1 at 1/3 HP	1 at 1/3 HP	1 at 1/3 HP
Motor RPM	1075	1075	1075	1075
<b>Indoor Fan—Type</b>	FC Centrifugal	FC Centrifugal	FC Centrifugal	FC Centrifugal
No. Used/Diameter in. [mm]	1/10x9 [254x229]	1/10x9 [254x229]	1/12x9 [305x229]	1/12x9 [305x229]
Drive Type/No. Speeds	Direct/3	Direct/3	Direct/3	Direct/3
No. Motors	1	1	1	1
Motor HP	3/4	3/4	1	1
Motor RPM	1075	1075	1075	1075
Motor Frame Size	48	48	48	48
<b>Filter—Type</b>	Field Supplied	Field Supplied	Field Supplied	Field Supplied
Furnished	No	No	No	No
(No.) Size Recommended in. [mm]	(1)1x24x24 [25x610x610]	(1)1x24x24 [25x610x610]	(1)1x24x30 [25x610x762]	(1)1x24x30 [25x610x762]
<b>Refrigerant Charge Oz. [g]</b>	161.2 [4570]	161.2 [4570]	172.8 [4899]	172.8 [4899]
<b>Weights</b>				
Net Weight lbs. [kg]	462 [210]	471 [214]	532 [241]	532 [241]
Ship Weight lbs. [kg]	502 [228]	511 [232]	577 [262]	577 [262]

See Page 14 for Notes.

[ ] Designates Metric Conversions

# GENERAL DATA—TZGE-4 SERIES

## NOMINAL SIZES 2-5 TONS [7.0-17.6 kW]

Model TZGE- Series	424JL040	424JL060	424JL080	430JL060
<b>Cooling Performance<sup>1</sup></b>				<b>CONTINUED</b> →
Gross Cooling Capacity Btu [kW]	24,400 [7.15]	24,400 [7.15]	24,400 [7.15]	29,600 [8.67]
EER/SEER <sup>2</sup>	12/14	12/14	12/14	12/14
Nominal CFM/ARI Rated CFM [L/s]	800/800 [378/378]	800/800 [378/378]	800/800 [378/378]	967/1000 [456/472]
ARI Net Cooling Capacity Btu [kW]	24,000 [7.03]	24,000 [7.03]	24,000 [7.03]	29,200 [8.56]
Net Sensible Capacity Btu [kW]	17,790 [5.21]	17,790 [5.21]	17,790 [5.21]	21,700 [6.36]
Net Latent Capacity Btu [kW]	6,210 [1.82]	6,210 [1.82]	6,210 [1.82]	7,500 [2.2]
Net System Power kW	2.01	2.01	2.01	2.43
<b>Heating Performance (Package Gas/Electric)<sup>3</sup></b>				
Heating Input Btu [kW]	40,000 [11.72]	60,000 [17.58]	80,000 [23.44]	60,000 [17.58]
Heating Output Btu [kW]	31,000 [9.08]	47,000 [13.77]	62,000 [18.17]	47,000 [13.77]
Temperature Rise Range °F [°C]	30-60 [16.7/33.3]	40-70 [22.2/38.9]	55-85 [30.6/47.2]	30-60 [16.7/33.3]
AFUE (%) <sup>4</sup>	80	80	80	80
Steady State Efficiency (%)	81	81	81	81
No. Burners	2	3	4	3
No. Stages	1	1	1	1
Gas Connection Pipe Size in. [mm]	0.5 [12.7]	0.5 [12.7]	0.5 [12.7]	0.5 [12.7]
<b>Compressor</b>				
No./Type	1/Scroll	1/Scroll	1/Scroll	1/Scroll
<b>Outdoor Sound Rating (dB)<sup>5</sup></b>	76	76	76	76
<b>Outdoor Coil—Fin Type</b>	Louvered	Louvered	Louvered	Louvered
Tube Type	Rifled	Rifled	Rifled	Rifled
Tube Size in. [mm] OD	0.375 [9.5]	0.375 [9.5]	0.375 [9.5]	0.375 [9.5]
Face Area sq. ft. [sq. m]	10.56 [0.98]	10.56 [0.98]	10.56 [0.98]	10.56 [0.98]
Rows / FPI [FPcm]	1 / 18 [7]	1 / 18 [7]	1 / 18 [7]	1 / 18 [7]
<b>Indoor Coil—Fin Type</b>	Louvered	Louvered	Louvered	Louvered
Tube Type	Rifled	Rifled	Rifled	Rifled
Tube Size in. [mm]	0.375 [9.5]	0.375 [9.5]	0.375 [9.5]	0.375 [9.5]
Face Area sq. ft. [sq. m]	5.54 [0.51]	5.54 [0.51]	5.54 [0.51]	5.54 [0.51]
Rows / FPI [FPcm]	2 / 15 [6]	2 / 15 [6]	2 / 15 [6]	2 / 15 [6]
Refrigerant Control	TX Valves	TX Valves	TX Valves	TX Valves
Drain Connection No./Size in. [mm]	1/0.75 [19.05]	1/0.75 [19.05]	1/0.75 [19.05]	1/0.75 [19.05]
<b>Outdoor Fan—Type</b>	Propeller	Propeller	Propeller	Propeller
No. Used/Diameter in. [mm]	1/22 [558.8]	1/22 [558.8]	1/22 [558.8]	1/22 [558.8]
Drive Type/No. Speeds	Direct/1	Direct/1	Direct/1	Direct/1
CFM [L/s]	2500 [1180]	2500 [1180]	2500 [1180]	2500 [1180]
No. Motors/HP	1 at 1/3 HP	1 at 1/3 HP	1 at 1/3 HP	1 at 1/3 HP
Motor RPM	1075	1075	1075	1075
<b>Indoor Fan—Type</b>	FC Centrifugal	FC Centrifugal	FC Centrifugal	FC Centrifugal
No. Used/Diameter in. [mm]	1/9x7 [229x178]	1/9x7 [229x178]	1/9x7 [229x178]	1/10x9 [254x229]
Drive Type/No. Speeds	Direct/2	Direct/2	Direct/2	Direct/3
No. Motors	1	1	1	1
Motor HP	1/3	1/3	1/3	1/2
Motor RPM	1075	1075	1075	1075
Motor Frame Size	48	48	48	48
<b>Filter—Type</b>	Field Supplied	Field Supplied	Field Supplied	Field Supplied
Furnished	No	No	No	No
(No.) Size Recommended in. [mm]	(1)1x20x20 [25x508x508]	(1)1x20x20 [25x508x508]	(1)1x20x20 [25x508x508]	(1)1x24x24 [25x610x610]
<b>Refrigerant Charge Oz. [g]</b>	77.8 [2206]	77.8 [2206]	77.8 [2206]	76.8 [2177]
<b>Weights</b>				
Net Weight lbs. [kg]	381 [173]	385 [175]	390 [177]	404 [183]
Ship Weight lbs. [kg]	421 [191]	425 [193]	430 [195]	444 [201]

See Page 14 for Notes.

[ ] Designates Metric Conversions

## NOMINAL SIZES 2-5 TONS [7.0-17.6 kW]

Model TZGE- Series	430JL080	430JL100	436CL080	436CL100
<b>Cooling Performance<sup>1</sup></b>				<b>CONTINUED</b> →
Gross Cooling Capacity Btu [kW]	29,600 [8.67]	29,600 [8.67]	36,800 [10.78]	36,800 [10.78]
EER/SEER <sup>2</sup>	12/14	12/14	12/14	12/14
Nominal CFM/ARI Rated CFM [L/s]	967/1000 [456/472]	967/1000 [456/472]	1200/1200 [566/566]	1200/1200 [566/566]
ARI Net Cooling Capacity Btu [kW]	29,200 [8.56]	29,200 [8.56]	36,000 [10.55]	36,000 [10.55]
Net Sensible Capacity Btu [kW]	21,700 [6.36]	21,700 [6.36]	26,420 [7.74]	26,420 [7.74]
Net Latent Capacity Btu [kW]	7,500 [2.2]	7,500 [2.2]	9,580 [2.81]	9,580 [2.81]
Net System Power kW	2.43	2.43	3	3
<b>Heating Performance (Package Gas/Electric)<sup>3</sup></b>				
Heating Input Btu [kW]	80,000 [23.44]	100,000 [29.3]	80,000 [23.44]	100,000 [29.3]
Heating Output Btu [kW]	62,000 [18.17]	77,000 [22.56]	64,800 [18.99]	81,000 [23.73]
Temperature Rise Range °F [°C]	40-70 [22.2/38.9]	45-85 [25/47.2]	40-70 [22.2/38.9]	45-85 [25/47.2]
AFUE (%) <sup>4</sup>	80	80	80	80
Steady State Efficiency (%)	81	81	81	81
No. Burners	4	5	4	5
No. Stages	1	1	1	1
Gas Connection Pipe Size in. [mm]	0.5 [12.7]	0.5 [12.7]	0.5 [12.7]	0.5 [12.7]
<b>Compressor</b>				
No./Type	1/Scroll	1/Scroll	1/Scroll	1/Scroll
<b>Outdoor Sound Rating (dB)<sup>5</sup></b>	76	76	76	76
<b>Outdoor Coil—Fin Type</b>	Louvered	Louvered	Louvered	Louvered
Tube Type	Rifled	Rifled	Rifled	Rifled
Tube Size in. [mm] OD	0.375 [9.5]	0.375 [9.5]	0.375 [9.5]	0.375 [9.5]
Face Area sq. ft. [sq. m]	10.56 [0.98]	10.56 [0.98]	14.8 [1.37]	14.8 [1.37]
Rows / FPI [FPcm]	1 / 18 [7]	1 / 18 [7]	1 / 22 [9]	1 / 22 [9]
<b>Indoor Coil—Fin Type</b>	Louvered	Louvered	Louvered	Louvered
Tube Type	Rifled	Rifled	Rifled	Rifled
Tube Size in. [mm]	0.375 [9.5]	0.375 [9.5]	0.375 [9.5]	0.375 [9.5]
Face Area sq. ft. [sq. m]	5.54 [0.51]	5.54 [0.51]	5.54 [0.51]	5.54 [0.51]
Rows / FPI [FPcm]	2 / 15 [6]	2 / 15 [6]	2 / 15 [6]	2 / 15 [6]
Refrigerant Control	TX Valves	TX Valves	TX Valves	TX Valves
Drain Connection No./Size in. [mm]	1/0.75 [19.05]	1/0.75 [19.05]	1/0.75 [19.05]	1/0.75 [19.05]
<b>Outdoor Fan—Type</b>	Propeller	Propeller	Propeller	Propeller
No. Used/Diameter in. [mm]	1/22 [558.8]	1/22 [558.8]	1/22 [558.8]	1/22 [558.8]
Drive Type/No. Speeds	Direct/1	Direct/1	Direct/1	Direct/1
CFM [L/s]	2500 [1180]	2500 [1180]	2700 [1274]	2700 [1274]
No. Motors/HP	1 at 1/3 HP	1 at 1/3 HP	1 at 1/3 HP	1 at 1/3 HP
Motor RPM	1075	1075	1075	1075
<b>Indoor Fan—Type</b>	FC Centrifugal	FC Centrifugal	FC Centrifugal	FC Centrifugal
No. Used/Diameter in. [mm]	1/10x9 [254x229]	1/10x9 [254x229]	1/10x9 [254x229]	1/10x9 [254x229]
Drive Type/No. Speeds	Direct/3	Direct/3	Direct/3	Direct/3
No. Motors	1	1	1	1
Motor HP	1/2	1/2	1/2	1/2
Motor RPM	1075	1075	1075	1075
Motor Frame Size	48	48	48	48
<b>Filter—Type</b>	Field Supplied	Field Supplied	Field Supplied	Field Supplied
Furnished	No	No	No	No
(No.) Size Recommended in. [mm]	(1)1x24x24 [25x610x610]	(1)1x24x24 [25x610x610]	(1)1x24x24 [25x610x610]	(1)1x24x24 [25x610x610]
<b>Refrigerant Charge Oz. [g]</b>	76.8 [2177]	76.8 [2177]	92.8 [2631]	92.8 [2631]
<b>Weights</b>				
Net Weight lbs. [kg]	409 [186]	414 [188]	422 [191]	426 [193]
Ship Weight lbs. [kg]	449 [204]	454 [206]	462 [210]	466 [211]

See Page 14 for Notes.

[ ] Designates Metric Conversions

# GENERAL DATA—TZGE-4 SERIES

## NOMINAL SIZES 2-5 TONS [7.0-17.6 kW]

Model TZGE- Series	436JL080	436JL100	442CL100	442JL100
<b>Cooling Performance<sup>1</sup></b>				<b>CONTINUED</b> →
Gross Cooling Capacity Btu [kW]	36,800 [10.78]	36,800 [10.78]	44,000 [12.89]	44,000 [12.89]
EER/SEER <sup>2</sup>	12/14	12/14	12/14	12/14
Nominal CFM/ARI Rated CFM [L/s]	1200/1200 [566/566]	1200/1200 [566/566]	1400/1400 [661/661]	1400/1400 [661/661]
ARI Net Cooling Capacity Btu [kW]	36,000 [10.55]	36,000 [10.55]	43,000 [12.6]	43,000 [12.6]
Net Sensible Capacity Btu [kW]	26,420 [7.74]	26,420 [7.74]	31,270 [9.16]	31,270 [9.16]
Net Latent Capacity Btu [kW]	9,580 [2.81]	9,580 [2.81]	11,730 [3.44]	11,730 [3.44]
Net System Power kW	3	3	3.58	3.58
<b>Heating Performance (Package Gas/Electric)<sup>3</sup></b>				
Heating Input Btu [kW]	80,000 [23.44]	100,000 [29.3]	100,000 [29.3]	100,000 [29.3]
Heating Output Btu [kW]	62,000 [18.17]	77,000 [22.56]	81,000 [23.73]	77,000 [22.56]
Temperature Rise Range °F [°C]	40-70 [22.2/38.9]	45-85 [25/47.2]	45-85 [25/47.2]	45-85 [25/47.2]
AFUE (%) <sup>4</sup>	80	80	80	80
Steady State Efficiency (%)	81	81	81	81
No. Burners	4	5	5	5
No. Stages	1	1	1	1
Gas Connection Pipe Size in. [mm]	0.5 [12.7]	0.5 [12.7]	0.5 [12.7]	0.5 [12.7]
<b>Compressor</b>				
No./Type	1/Scroll	1/Scroll	1/Scroll	1/Scroll
<b>Outdoor Sound Rating (dB)<sup>5</sup></b>	76	76	76	76
<b>Outdoor Coil—Fin Type</b>	Louvered	Louvered	Louvered	Louvered
Tube Type	Rifled	Rifled	Rifled	Rifled
Tube Size in. [mm] OD	0.375 [9.5]	0.375 [9.5]	0.375 [9.5]	0.375 [9.5]
Face Area sq. ft. [sq. m]	14.8 [1.37]	14.8 [1.37]	16.65 [1.55]	16.65 [1.55]
Rows / FPI [FPcm]	1 / 22 [9]	1 / 22 [9]	1 / 22 [9]	1 / 22 [9]
<b>Indoor Coil—Fin Type</b>	Louvered	Louvered	Louvered	Louvered
Tube Type	Rifled	Rifled	Rifled	Rifled
Tube Size in. [mm]	0.375 [9.5]	0.375 [9.5]	0.375 [9.5]	0.375 [9.5]
Face Area sq. ft. [sq. m]	5.54 [0.51]	5.54 [0.51]	7.39 [0.69]	7.39 [0.69]
Rows / FPI [FPcm]	2 / 15 [6]	2 / 15 [6]	2 / 15 [6]	2 / 15 [6]
Refrigerant Control	TX Valves	TX Valves	TX Valves	TX Valves
Drain Connection No./Size in. [mm]	1/0.75 [19.05]	1/0.75 [19.05]	1/0.75 [19.05]	1/0.75 [19.05]
<b>Outdoor Fan—Type</b>	Propeller	Propeller	Propeller	Propeller
No. Used/Diameter in. [mm]	1/22 [558.8]	1/22 [558.8]	1/22 [558.8]	1/22 [558.8]
Drive Type/No. Speeds	Direct/1	Direct/1	Direct/1	Direct/1
CFM [L/s]	2700 [1274]	2700 [1274]	3500 [1652]	3500 [1652]
No. Motors/HP	1 at 1/3 HP	1 at 1/3 HP	1 at 1/3 HP	1 at 1/3 HP
Motor RPM	1075	1075	1075	1075
<b>Indoor Fan—Type</b>	FC Centrifugal	FC Centrifugal	FC Centrifugal	FC Centrifugal
No. Used/Diameter in. [mm]	1/10x9 [254x229]	1/10x9 [254x229]	1/10x9 [254x229]	1/10x9 [254x229]
Drive Type/No. Speeds	Direct/3	Direct/3	Direct/3	Direct/3
No. Motors	1	1	1	1
Motor HP	1/2	1/2	1/2	1/2
Motor RPM	1075	1075	1075	1075
Motor Frame Size	48	48	48	48
<b>Filter—Type</b>	Field Supplied	Field Supplied	Field Supplied	Field Supplied
Furnished	No	No	No	No
(No.) Size Recommended in. [mm]	(1)1x24x24 [25x610x610]	(1)1x24x24 [25x610x610]	(1)1x24x24 [25x610x610]	(1)1x24x24 [25x610x610]
<b>Refrigerant Charge Oz. [g]</b>	92.8 [2631]	92.8 [2631]	112 [3175]	112 [3175]
<b>Weights</b>				
Net Weight lbs. [kg]	422 [191]	426 [193]	437 [198]	437 [198]
Ship Weight lbs. [kg]	462 [210]	466 [211]	477 [216]	477 [216]

See Page 14 for Notes.

[ ] Designates Metric Conversions

## NOMINAL SIZES 2-5 TONS [7.0-17.6 kW]

Model TZGE- Series	448CL100	448JL100	460CL100	460JL100
<b>Cooling Performance<sup>1</sup></b>				<b>CONTINUED</b> →
Gross Cooling Capacity Btu [kW]	50,500 [14.8]	50,500 [14.8]	59,500 [17.43]	59,500 [17.43]
EER/SEER <sup>2</sup>	12/14	12/14	10.8/14	10.8/14
Nominal CFM/ARI Rated CFM [L/s]	1600/1600 [755/755]	1600/1600 [755/755]	2000/1850 [944/873]	2000/1850 [944/873]
ARI Net Cooling Capacity Btu [kW]	49,000 [14.36]	49,000 [14.36]	57,500 [16.85]	57,500 [16.85]
Net Sensible Capacity Btu [kW]	34,990 [10.25]	34,990 [10.25]	40,460 [11.85]	40,460 [11.85]
Net Latent Capacity Btu [kW]	14,010 [4.1]	14,010 [4.1]	17,040 [4.99]	17,040 [4.99]
Net System Power kW	4.08	4.08	5.32	5.32
<b>Heating Performance (Package Gas/Electric)<sup>3</sup></b>				
Heating Input Btu [kW]	100,000 [29.3]	100,000 [29.3]	100,000 [29.3]	100,000 [29.3]
Heating Output Btu [kW]	81,000 [23.73]	77,000 [22.56]	81,000 [23.73]	77,000 [22.56]
Temperature Rise Range °F [°C]	45-85 [25/47.2]	45-85 [25/47.2]	45-85 [25/47.2]	45-85 [25/47.2]
AFUE (%) <sup>4</sup>	80	80	80	80
Steady State Efficiency (%)	81	81	81	81
No. Burners	5	5	5	5
No. Stages	1	1	1	1
Gas Connection Pipe Size in. [mm]	0.5 [12.7]	0.5 [12.7]	0.5 [12.7]	0.5 [12.7]
<b>Compressor</b>				
No./Type	1/Scroll	1/Scroll	1/Scroll	1/Scroll
<b>Outdoor Sound Rating (dB)<sup>5</sup></b>	78	78	78	78
<b>Outdoor Coil—Fin Type</b>	Louvered	Louvered	Louvered	Louvered
Tube Type	Rifled	Rifled	Rifled	Rifled
Tube Size in. [mm] OD	0.375 [9.5]	0.375 [9.5]	0.375 [9.5]	0.375 [9.5]
Face Area sq. ft. [sq. m]	16.23 [1.51]	16.23 [1.51]	16.23 [1.51]	16.23 [1.51]
Rows / FPI [FPcm]	2 / 22 [9]	2 / 22 [9]	2 / 22 [9]	2 / 22 [9]
<b>Indoor Coil—Fin Type</b>	Louvered	Louvered	Louvered	Louvered
Tube Type	Rifled	Rifled	Rifled	Rifled
Tube Size in. [mm]	0.375 [9.5]	0.375 [9.5]	0.375 [9.5]	0.375 [9.5]
Face Area sq. ft. [sq. m]	7.39 [0.69]	7.39 [0.69]	7.39 [0.69]	7.39 [0.69]
Rows / FPI [FPcm]	2 / 15 [6]	2 / 15 [6]	2 / 15 [6]	2 / 15 [6]
Refrigerant Control	TX Valves	TX Valves	TX Valves	TX Valves
Drain Connection No./Size in. [mm]	1/0.75 [19.05]	1/0.75 [19.05]	1/0.75 [19.05]	1/0.75 [19.05]
<b>Outdoor Fan—Type</b>	Propeller	Propeller	Propeller	Propeller
No. Used/Diameter in. [mm]	1/22 [558.8]	1/22 [558.8]	1/22 [558.8]	1/22 [558.8]
Drive Type/No. Speeds	Direct/1	Direct/1	Direct/1	Direct/1
CFM [L/s]	3300 [1557]	3300 [1557]	3300 [1557]	3300 [1557]
No. Motors/HP	1 at 1/3 HP	1 at 1/3 HP	1 at 1/3 HP	1 at 1/3 HP
Motor RPM	1075	1075	1075	1075
<b>Indoor Fan—Type</b>	FC Centrifugal	FC Centrifugal	FC Centrifugal	FC Centrifugal
No. Used/Diameter in. [mm]	1/10x9 [254x229]	1/10x9 [254x229]	1/12x9 [305x229]	1/12x9 [305x229]
Drive Type/No. Speeds	Direct/3	Direct/3	Direct/3	Direct/3
No. Motors	1	1	1	1
Motor HP	3/4	3/4	1	1
Motor RPM	1075	1075	1075	1075
Motor Frame Size	48	48	48	48
<b>Filter—Type</b>	Field Supplied	Field Supplied	Field Supplied	Field Supplied
Furnished	No	No	No	No
(No.) Size Recommended in. [mm]	(1)1x24x24 [25x610x610]	(1)1x24x24 [25x610x610]	(1)1x24x30 [25x610x762]	(1)1x24x30 [25x610x762]
<b>Refrigerant Charge Oz. [g]</b>	161.2 [4570]	161.2 [4570]	172.8 [4899]	172.8 [4899]
<b>Weights</b>				
Net Weight lbs. [kg]	462 [210]	471 [214]	532 [241]	532 [241]
Ship Weight lbs. [kg]	502 [228]	511 [232]	577 [262]	577 [262]

See Page 14 for Notes.

[ ] Designates Metric Conversions

## GENERAL DATA—TZGE-3/TZGE-4 SERIES

### NOTES:

1. Cooling Performance is rated at 95° F ambient, 80° F entering dry bulb, 67° F entering wet bulb. Gross capacity does not include the effect of fan motor heat. ARI capacity is net and includes the effect of fan motor heat. Units are suitable for operation in CFM range shown in airflow tables. Units are certified in accordance with the Unitary Air Conditioner Equipment certification program, which is based on ARI Standard 210/240 or 360.
2. EER and/or SEER are rated at ARI conditions and in accordance with DOE test procedures.
3. Heating Performance limit settings and rating data were established and approved under laboratory test conditions using American National Standard Institute standards. Ratings shown are for elevations up to 2000 feet. For elevations above 2000 feet, ratings should be reduced at the rate of 4% for each 1000 feet above sea level.
4. AFUE is rated in accordance with DOE test procedures.
5. Outdoor Sound Rating shown is tested in accordance with ARI Standard 270.

# SYSTEMS PERFORMANCE—TZGE-3 SERIES

## GROSS SYSTEMS PERFORMANCE DATA—324

		ENTERING INDOOR AIR @ 80°F [26.7°C] dbE ①									
wbE		71°F [21.7°C]			67°F [19.4°C]			63°F [17.2°C]			
CFM [L/s]		880 [415]	800 [378]	680 [321]	880 [415]	800 [378]	680 [321]	880 [415]	800 [378]	680 [321]	
DR ①		.19	.17	.16	.19	.17	.16	.19	.17	.16	
OUTDOOR DRY BULB TEMPERATURE °F [°C]	75 [23.9]	Total BTUH [kW]	29.6 [8.67]	29.0 [8.50]	28.5 [8.35]	27.8 [8.15]	27.3 [8.00]	26.8 [7.85]	26.6 [7.80]	26.1 [7.65]	25.7 [7.53]
		Sens BTUH [kW]	17.6 [5.16]	16.8 [4.92]	16.0 [4.69]	20.7 [6.07]	19.8 [5.80]	18.8 [5.51]	22.1 [6.48]	21.2 [6.21]	20.2 [5.92]
		Power	1.5	1.5	1.5	1.5	1.5	1.5	1.5	1.5	1.5
	80 [26.7]	Total BTUH [kW]	29.0 [8.50]	28.5 [8.35]	28.0 [8.21]	27.2 [7.97]	26.8 [7.85]	26.3 [7.71]	26.0 [7.62]	25.6 [7.50]	25.1 [7.36]
		Sens BTUH [kW]	17.3 [5.07]	16.5 [4.84]	15.7 [4.60]	20.3 [5.95]	19.4 [5.69]	18.5 [5.42]	21.8 [6.39]	20.8 [6.10]	19.9 [5.83]
		Power	1.6	1.6	1.6	1.6	1.6	1.6	1.6	1.6	1.6
	85 [29.4]	Total BTUH [kW]	28.3 [8.29]	27.8 [8.15]	27.3 [8.00]	26.5 [7.77]	26.1 [7.65]	25.6 [7.50]	25.3 [7.41]	24.9 [7.30]	24.4 [7.15]
		Sens BTUH [kW]	16.9 [4.95]	16.1 [4.72]	15.4 [4.51]	19.9 [5.83]	19.0 [5.57]	18.1 [5.30]	21.4 [6.27]	20.4 [5.98]	19.5 [5.71]
		Power	1.7	1.7	1.7	1.7	1.7	1.7	1.7	1.7	1.7
	90 [32.2]	Total BTUH [kW]	27.5 [8.06]	27.0 [7.91]	26.5 [7.77]	25.7 [7.53]	25.3 [7.41]	24.8 [7.27]	24.5 [7.18]	24.1 [7.06]	23.7 [6.95]
Sens BTUH [kW]		16.4 [4.81]	15.7 [4.60]	14.9 [4.37]	19.5 [5.71]	18.6 [5.45]	17.7 [5.19]	20.9 [6.13]	20.0 [5.86]	19.1 [5.60]	
Power		1.8	1.8	1.8	1.8	1.8	1.8	1.8	1.8	1.8	
95 [35]	Total BTUH [kW]	26.6 [7.80]	26.1 [7.65]	25.7 [7.53]	24.9 [7.30]	24.4 [7.15]	24.0 [7.03]	23.7 [6.95]	23.2 [6.80]	22.8 [6.68]	
	Sens BTUH [kW]	15.9 [4.66]	15.2 [4.45]	14.5 [4.25]	19.0 [5.57]	18.2 [5.33]	17.3 [5.07]	20.5 [6.01]	19.6 [5.74]	18.6 [5.45]	
	Power	1.9	1.9	1.9	1.9	1.9	1.9	1.9	1.9	1.9	
100 [37.8]	Total BTUH [kW]	25.7 [7.53]	25.3 [7.41]	24.8 [7.27]	24.0 [7.03]	23.5 [6.89]	23.1 [6.77]	22.8 [6.68]	22.4 [6.56]	22.0 [6.45]	
	Sens BTUH [kW]	15.5 [4.54]	14.8 [4.34]	14.1 [4.13]	18.6 [5.45]	17.8 [5.22]	16.9 [4.95]	20.0 [5.86]	19.2 [5.63]	18.3 [5.36]	
	Power	2.0	2.0	2.0	2.0	2.0	2.0	2.0	2.0	2.0	
105 [40.6]	Total BTUH [kW]	24.9 [7.30]	24.4 [7.15]	24.0 [7.03]	23.1 [6.77]	22.7 [6.65]	22.3 [6.54]	21.9 [6.42]	21.5 [6.30]	21.1 [6.18]	
	Sens BTUH [kW]	15.1 [4.43]	14.5 [4.25]	13.8 [4.04]	18.2 [5.33]	17.4 [5.10]	16.6 [4.86]	19.7 [5.77]	18.8 [5.51]	17.9 [5.25]	
	Power	2.1	2.1	2.1	2.1	2.1	2.1	2.1	2.1	2.1	
110 [43.3]	Total BTUH [kW]	24.0 [7.03]	23.6 [6.92]	23.2 [6.80]	22.3 [6.54]	21.9 [6.42]	21.5 [6.30]	21.1 [6.18]	20.7 [6.07]	20.3 [5.95]	
	Sens BTUH [kW]	14.9 [4.37]	14.2 [4.16]	13.6 [3.99]	18.0 [5.28]	17.2 [5.04]	16.4 [4.81]	19.4 [5.69]	18.6 [5.45]	17.7 [5.19]	
	Power	2.2	2.2	2.1	2.2	2.2	2.1	2.2	2.2	2.1	
115 [46.1]	Total BTUH [kW]	23.3 [6.83]	22.9 [6.71]	22.4 [6.56]	21.5 [6.30]	21.1 [6.18]	20.8 [6.10]	20.3 [5.95]	20.0 [5.86]	19.6 [5.74]	
	Sens BTUH [kW]	14.8 [4.34]	14.1 [4.13]	13.4 [3.93]	17.8 [5.22]	17.0 [4.98]	16.2 [4.75]	19.3 [5.66]	18.4 [5.39]	17.6 [5.16]	
	Power	2.3	2.3	2.2	2.3	2.3	2.2	2.3	2.3	2.2	

## GROSS SYSTEMS PERFORMANCE DATA—330

		ENTERING INDOOR AIR @ 80°F [26.7°C] dbE ①									
wbE		71°F [21.7°C]			67°F [19.4°C]			63°F [17.2°C]			
CFM [L/s]		1100 [519]	1000 [472]	850 [401]	1100 [519]	1000 [472]	850 [401]	1100 [519]	1000 [472]	850 [401]	
DR ①		.22	.20	.19	.22	.20	.19	.22	.20	.19	
OUTDOOR DRY BULB TEMPERATURE °F [°C]	75 [23.9]	Total BTUH [kW]	36.7 [10.76]	36.0 [10.55]	35.4 [10.37]	34.5 [10.11]	33.9 [9.94]	33.3 [9.76]	33.1 [9.70]	32.6 [9.55]	32.0 [9.38]
		Sens BTUH [kW]	21.3 [6.24]	20.4 [5.98]	19.4 [5.69]	25.4 [7.44]	24.3 [7.12]	23.2 [6.80]	27.1 [7.94]	25.9 [7.59]	24.7 [7.24]
		Power	1.8	1.8	1.8	1.8	1.8	1.8	1.8	1.8	1.8
	80 [26.7]	Total BTUH [kW]	35.8 [10.49]	35.2 [10.32]	34.5 [10.11]	33.6 [9.85]	33.0 [9.67]	32.4 [9.50]	32.2 [9.44]	31.7 [9.29]	31.1 [9.11]
		Sens BTUH [kW]	20.7 [6.07]	19.8 [5.80]	18.9 [5.54]	24.8 [7.27]	23.7 [6.95]	22.6 [6.62]	26.5 [7.77]	25.3 [7.41]	24.1 [7.06]
		Power	1.9	1.9	1.9	1.9	1.9	1.9	1.9	1.9	1.9
	85 [29.4]	Total BTUH [kW]	34.8 [10.20]	34.2 [10.02]	33.5 [9.82]	32.6 [9.55]	32.0 [9.38]	31.4 [9.20]	31.2 [9.14]	30.7 [9.00]	30.1 [8.82]
		Sens BTUH [kW]	20.1 [5.89]	19.2 [5.63]	18.3 [5.36]	24.2 [7.09]	23.1 [6.77]	22.0 [6.45]	25.9 [7.59]	24.7 [7.24]	23.6 [6.92]
		Power	2.0	2.0	2.0	2.0	2.0	2.0	2.0	2.0	2.0
	90 [32.2]	Total BTUH [kW]	33.7 [9.88]	33.1 [9.70]	32.5 [9.52]	31.5 [9.23]	30.9 [9.06]	30.3 [8.88]	30.1 [8.82]	29.6 [8.67]	29.0 [8.50]
Sens BTUH [kW]		19.5 [5.71]	18.6 [5.45]	17.7 [5.19]	23.6 [6.92]	22.5 [6.59]	21.5 [6.30]	25.2 [7.39]	24.1 [7.06]	23.0 [6.74]	
Power		2.2	2.1	2.1	2.2	2.1	2.1	2.1	2.1	2.1	
95 [35]	Total BTUH [kW]	32.5 [9.52]	31.9 [9.35]	31.3 [9.17]	30.3 [8.88]	29.7 [8.70]	29.2 [8.56]	28.9 [8.47]	28.4 [8.32]	27.9 [8.18]	
	Sens BTUH [kW]	18.8 [5.51]	18.0 [5.28]	17.2 [5.04]	23.0 [6.74]	21.9 [6.42]	20.9 [6.13]	24.6 [7.21]	23.5 [6.89]	22.4 [6.56]	
	Power	2.3	2.2	2.2	2.3	2.2	2.2	2.3	2.2	2.2	
100 [37.8]	Total BTUH [kW]	31.2 [9.14]	30.6 [8.97]	30.1 [8.82]	29.0 [8.50]	28.5 [8.35]	28.0 [8.21]	27.7 [8.12]	27.2 [7.97]	26.7 [7.83]	
	Sens BTUH [kW]	18.2 [5.33]	17.4 [5.10]	16.6 [4.86]	22.3 [6.54]	21.3 [6.24]	20.3 [5.95]	24.0 [7.03]	22.9 [6.71]	21.8 [6.39]	
	Power	2.4	2.4	2.3	2.4	2.4	2.3	2.4	2.4	2.3	
105 [40.6]	Total BTUH [kW]	29.9 [8.76]	29.4 [8.62]	28.8 [8.44]	27.7 [8.12]	27.2 [7.97]	26.7 [7.83]	26.3 [7.71]	25.9 [7.59]	25.4 [7.44]	
	Sens BTUH [kW]	17.5 [5.13]	16.7 [4.89]	16.0 [4.69]	21.6 [6.33]	20.7 [6.07]	19.7 [5.77]	23.3 [6.83]	22.3 [6.54]	21.2 [6.21]	
	Power	2.5	2.5	2.5	2.5	2.5	2.5	2.5	2.5	2.4	
110 [43.3]	Total BTUH [kW]	28.5 [8.35]	28.0 [8.21]	27.5 [8.06]	26.3 [7.71]	25.9 [7.59]	25.4 [7.44]	25.0 [7.33]	24.5 [7.18]	24.1 [7.06]	
	Sens BTUH [kW]	16.8 [4.92]	16.0 [4.69]	15.3 [4.48]	20.9 [6.13]	20.0 [5.86]	19.0 [5.57]	22.6 [6.62]	21.6 [6.33]	20.6 [6.04]	
	Power	2.6	2.6	2.6	2.6	2.6	2.6	2.6	2.6	2.6	
115 [46.1]	Total BTUH [kW]	27.2 [7.97]	26.7 [7.83]	26.2 [7.68]	25.0 [7.33]	24.5 [7.18]	24.1 [7.06]	23.6 [6.92]	23.2 [6.80]	22.8 [6.68]	
	Sens BTUH [kW]	16.0 [4.69]	15.3 [4.48]	14.6 [4.28]	20.1 [5.89]	19.2 [5.63]	18.3 [5.36]	21.8 [6.39]	20.8 [6.10]	19.8 [5.80]	
	Power	2.7	2.7	2.7	2.7	2.7	2.7	2.7	2.7	2.7	

DR —Depression ratio  
dbE—Entering air dry bulb  
wbE—Entering air wet bulb

Total —Total capacity x 1000 BTUH  
Sens —Sensible capacity x 1000 BTUH  
Power—KW input

NOTES: ① When the entering air dry bulb is other than 80°F [27°C], adjust the sensible capacity from the table by adding  $[1.10 \times \text{CFM} \times (1 - \text{DR}) \times (\text{dbE} - 80)]$ .

[ ] Designates Metric Conversions



# SYSTEMS PERFORMANCE—TZGE-3 SERIES

## GROSS SYSTEMS PERFORMANCE DATA—336

		ENTERING INDOOR AIR @ 80°F [26.7°C] dbE ①									
wbE		71°F [21.7°C]			67°F [19.4°C]			63°F [17.2°C]			
CFM [L/s]		1320 [623]	1200 [566]	1080 [510]	1320 [623]	1200 [566]	1080 [510]	1320 [623]	1200 [566]	1080 [510]	
DR ①		.17	.15	.13	.17	.15	.13	.17	.15	.13	
OUTDOOR DRY BULB TEMPERATURE °F [°C]	75 [23.9]	Total BTUH [kW] Sens BTUH [kW] Power	44.9 [13.16] 26.5 [7.77] 2.3	44.1 [12.92] 25.3 [7.41] 2.2	43.3 [12.69] 24.1 [7.06] 2.2	42.3 [12.40] 31.6 [9.26] 2.2	41.5 [12.16] 30.2 [8.85] 2.2	40.7 [11.93] 28.8 [8.44] 2.2	40.6 [11.90] 33.5 [9.82] 2.2	39.9 [11.69] 32.0 [9.38] 2.2	39.2 [11.49] 30.5 [8.94] 2.2
	80 [26.7]	Total BTUH [kW] Sens BTUH [kW] Power	44.2 [12.95] 26.2 [7.68] 2.4	43.4 [12.72] 25.0 [7.33] 2.4	42.6 [12.48] 23.8 [6.98] 2.4	41.6 [12.19] 31.3 [9.17] 2.4	40.8 [11.96] 29.9 [8.76] 2.4	40.1 [11.75] 28.5 [8.35] 2.3	39.9 [11.69] 33.2 [9.73] 2.4	39.2 [11.49] 31.7 [9.29] 2.4	38.5 [11.28] 30.2 [8.85] 2.3
	85 [29.4]	Total BTUH [kW] Sens BTUH [kW] Power	43.1 [12.63] 25.6 [7.50] 2.5	42.4 [12.43] 24.4 [7.15] 2.5	41.6 [12.19] 23.3 [6.83] 2.5	40.5 [11.87] 30.7 [9.00] 2.5	39.8 [11.66] 29.3 [8.59] 2.5	39.1 [11.46] 27.9 [8.18] 2.5	38.9 [11.40] 32.6 [9.55] 2.5	38.2 [11.20] 31.1 [9.11] 2.5	37.5 [10.99] 29.7 [8.70] 2.5
	90 [32.2]	Total BTUH [kW] Sens BTUH [kW] Power	41.8 [12.25] 24.8 [7.27] 2.7	41.1 [12.05] 23.7 [6.95] 2.7	40.3 [11.81] 22.6 [6.62] 2.6	39.2 [11.49] 29.9 [8.76] 2.7	38.5 [11.28] 28.6 [8.38] 2.6	37.8 [11.08] 27.3 [8.00] 2.6	37.6 [11.02] 31.8 [9.32] 2.7	36.9 [10.81] 30.4 [8.91] 2.6	36.2 [10.61] 29.0 [8.50] 2.6
	95 [35]	Total BTUH [kW] Sens BTUH [kW] Power	40.3 [11.81] 24.0 [7.03] 2.8	39.6 [11.61] 22.9 [6.71] 2.8	38.9 [11.40] 21.9 [6.42] 2.8	37.7 [11.05] 29.1 [8.53] 2.8	37.0 [10.84] 27.8 [8.15] 2.8	36.4 [10.67] 26.5 [7.77] 2.8	36.1 [10.58] 31.0 [9.09] 2.8	35.4 [10.37] 29.6 [8.67] 2.8	34.8 [10.20] 28.3 [8.29] 2.8
	100 [37.8]	Total BTUH [kW] Sens BTUH [kW] Power	38.8 [11.37] 23.2 [6.80] 3.0	38.1 [11.17] 22.1 [6.48] 2.9	37.4 [10.96] 21.1 [6.18] 2.9	36.1 [10.58] 28.3 [8.29] 3.0	35.5 [10.40] 27.0 [7.91] 2.9	34.8 [10.20] 25.8 [7.56] 2.9	34.5 [10.11] 30.2 [8.85] 2.9	33.9 [9.94] 28.8 [8.44] 2.9	33.3 [9.76] 27.5 [8.06] 2.9
	105 [40.6]	Total BTUH [kW] Sens BTUH [kW] Power	37.2 [10.90] 22.4 [6.56] 3.1	36.5 [10.70] 21.4 [6.27] 3.1	35.9 [10.52] 20.4 [5.98] 3.1	34.6 [10.14] 27.5 [8.06] 3.1	34.0 [9.96] 26.3 [7.71] 3.1	33.3 [9.76] 25.0 [7.33] 3.0	32.9 [9.64] 29.4 [8.62] 3.1	32.3 [9.47] 28.1 [8.24] 3.1	31.8 [9.32] 26.8 [7.85] 3.0
	110 [43.3]	Total BTUH [kW] Sens BTUH [kW] Power	35.7 [10.46] 21.8 [6.39] 3.3	35.1 [10.29] 20.8 [6.10] 3.2	34.5 [10.11] 19.8 [5.80] 3.2	33.1 [9.70] 26.9 [7.88] 3.2	32.5 [9.52] 25.7 [7.53] 3.2	31.9 [9.35] 24.5 [7.18] 3.2	31.5 [9.23] 28.8 [8.44] 3.2	30.9 [9.06] 27.5 [8.06] 3.2	30.4 [8.91] 26.2 [7.68] 3.2
	115 [46.1]	Total BTUH [kW] Sens BTUH [kW] Power	34.5 [10.11] 21.3 [6.24] 3.4	33.9 [9.94] 20.4 [5.98] 3.4	33.3 [9.76] 19.4 [5.69] 3.3	31.9 [9.35] 26.4 [7.74] 3.4	31.3 [9.17] 25.2 [7.39] 3.4	30.7 [9.00] 24.1 [7.06] 3.3	30.2 [8.85] 28.3 [8.29] 3.4	29.7 [8.70] 27.1 [7.94] 3.3	29.2 [8.56] 25.8 [7.56] 3.3

## GROSS SYSTEMS PERFORMANCE DATA—342

		ENTERING INDOOR AIR @ 80°F [26.7°C] dbE ①									
wbE		71°F [21.7°C]			67°F [19.4°C]			63°F [17.2°C]			
CFM [L/s]		1540 [727]	1400 [661]	1260 [595]	1540 [727]	1400 [661]	1260 [595]	1540 [727]	1400 [661]	1260 [595]	
DR ①		.18	.17	.15	.18	.17	.15	.18	.17	.15	
OUTDOOR DRY BULB TEMPERATURE °F [°C]	75 [23.9]	Total BTUH [kW] Sens BTUH [kW] Power	53.6 [15.71] 31.1 [9.11] 2.6	52.6 [15.42] 29.7 [8.70] 2.6	51.7 [15.15] 28.3 [8.29] 2.6	50.3 [14.74] 36.6 [10.73] 2.6	49.4 [14.48] 34.9 [10.23] 2.6	48.5 [14.21] 33.3 [9.76] 2.6	48.6 [14.24] 39.7 [11.63] 2.6	47.7 [13.98] 37.9 [11.11] 2.6	46.8 [13.72] 36.2 [10.61] 2.6
	80 [26.7]	Total BTUH [kW] Sens BTUH [kW] Power	52.1 [15.27] 30.4 [8.91] 2.8	51.1 [14.98] 29.0 [8.50] 2.7	50.2 [14.71] 27.7 [8.12] 2.7	48.7 [14.27] 35.9 [10.52] 2.8	47.9 [14.04] 34.3 [10.05] 2.7	47.0 [13.77] 32.7 [9.58] 2.7	47.0 [13.77] 39.0 [11.43] 2.8	46.2 [13.54] 37.3 [10.93] 2.7	45.4 [13.31] 35.5 [10.40] 2.7
	85 [29.4]	Total BTUH [kW] Sens BTUH [kW] Power	50.6 [14.83] 29.7 [8.70] 2.9	49.7 [14.57] 28.4 [8.32] 2.9	48.8 [14.30] 27.1 [7.94] 2.9	47.3 [13.86] 35.2 [10.32] 2.9	46.4 [13.60] 33.6 [9.85] 2.9	45.6 [13.36] 32.0 [9.38] 2.9	45.6 [13.36] 38.3 [11.22] 2.9	44.8 [13.13] 36.6 [10.73] 2.9	44.0 [12.90] 34.9 [10.23] 2.9
	90 [32.2]	Total BTUH [kW] Sens BTUH [kW] Power	49.3 [14.45] 29.0 [8.50] 3.1	48.4 [14.18] 27.7 [8.12] 3.1	47.5 [13.92] 26.4 [7.74] 3.0	45.9 [13.45] 34.5 [10.11] 3.1	45.1 [13.22] 32.9 [9.64] 3.1	44.3 [12.98] 31.4 [9.20] 3.0	44.2 [12.95] 37.6 [11.02] 3.1	43.4 [12.72] 35.9 [10.52] 3.1	42.6 [12.48] 34.3 [10.05] 3.0
	95 [35]	Total BTUH [kW] Sens BTUH [kW] Power	47.9 [14.04] 28.3 [8.29] 3.2	47.1 [13.80] 27.1 [7.94] 3.2	46.2 [13.54] 25.8 [7.56] 3.2	44.6 [13.07] 33.8 [9.91] 3.2	43.8 [12.84] 32.3 [9.47] 3.2	43.0 [12.60] 30.8 [9.03] 3.2	42.9 [12.57] 36.9 [10.81] 3.2	42.1 [12.34] 35.3 [10.35] 3.2	41.4 [12.13] 33.6 [9.85] 3.2
	100 [37.8]	Total BTUH [kW] Sens BTUH [kW] Power	46.6 [13.66] 27.6 [8.09] 3.4	45.8 [13.42] 26.4 [7.74] 3.4	44.9 [13.16] 25.1 [7.36] 3.4	43.2 [12.66] 33.1 [9.70] 3.4	42.5 [12.46] 31.6 [9.26] 3.4	41.7 [12.22] 30.1 [8.82] 3.3	41.6 [12.19] 36.2 [10.61] 3.4	40.8 [11.96] 34.6 [10.14] 3.4	40.1 [11.75] 33.0 [9.67] 3.3
	105 [40.6]	Total BTUH [kW] Sens BTUH [kW] Power	45.3 [13.28] 26.9 [7.88] 3.6	44.4 [13.01] 25.7 [7.53] 3.5	43.6 [12.78] 24.5 [7.18] 3.5	41.9 [12.28] 32.3 [9.47] 3.6	41.2 [12.07] 30.9 [9.06] 3.5	40.4 [11.84] 29.4 [8.62] 3.5	40.2 [11.78] 35.5 [10.40] 3.6	39.5 [11.58] 33.9 [9.94] 3.5	38.8 [11.37] 32.3 [9.47] 3.5
	110 [43.3]	Total BTUH [kW] Sens BTUH [kW] Power	43.9 [12.87] 26.1 [7.65] 3.7	43.1 [12.63] 24.9 [7.30] 3.7	42.3 [12.40] 23.7 [6.95] 3.7	40.5 [11.87] 31.5 [9.23] 3.7	39.8 [11.66] 30.1 [8.82] 3.7	39.1 [11.46] 28.7 [8.41] 3.7	38.8 [11.37] 34.7 [10.17] 3.7	38.2 [11.20] 33.1 [9.70] 3.7	37.5 [10.99] 31.6 [9.26] 3.7
	115 [46.1]	Total BTUH [kW] Sens BTUH [kW] Power	42.4 [12.43] 25.2 [7.39] 3.9	41.7 [12.22] 24.1 [7.06] 3.9	40.9 [11.99] 23.0 [6.74] 3.8	39.1 [11.46] 30.7 [9.00] 3.9	38.4 [11.25] 29.3 [8.59] 3.8	37.7 [11.05] 28.0 [8.21] 3.8	37.4 [10.96] 33.8 [9.91] 3.9	36.7 [10.76] 32.3 [9.47] 3.8	36.1 [10.58] 30.8 [9.03] 3.8

DR —Depression ratio  
dbE—Entering air dry bulb  
wbE—Entering air wet bulb

Total —Total capacity x 1000 BTUH  
Sens —Sensible capacity x 1000 BTUH  
Power—KW input

NOTES: ① When the entering air dry bulb is other than 80°F [27°C], adjust the sensible capacity from the table by adding  $[1.10 \times \text{CFM} \times (1 - \text{DR}) \times (\text{dbE} - 80)]$ .

[ ] Designates Metric Conversions

# SYSTEMS PERFORMANCE—TZGE-3 SERIES

## GROSS SYSTEMS PERFORMANCE DATA—348

		ENTERING INDOOR AIR @ 80°F [26.7°C] dbE ①									
		wbE	71°F [21.7°C]			67°F [19.4°C]			63°F [17.2°C]		
			CFM [L/s]	1760 [831]	1600 [755]	1440 [680]	1760 [831]	1600 [755]	1440 [680]	1760 [831]	1600 [755]
		DR ①	.22	.20	.19	.22	.20	.19	.22	.20	.19
OUTDOOR DRY BULB TEMPERATURE °F [°C]	75 [23.9]	Total BTUH [kW]	61.6 [18.05]	60.5 [17.73]	59.4 [17.41]	58.0 [17.00]	57.0 [16.71]	55.9 [16.38]	55.3 [16.21]	54.3 [15.91]	53.3 [15.62]
		Sens BTUH [kW]	34.8 [10.20]	33.2 [9.73]	31.7 [9.29]	41.6 [12.19]	39.7 [11.63]	37.9 [11.11]	44.4 [13.01]	42.4 [12.43]	40.4 [11.84]
		Power	3.0	2.9	2.9	2.9	2.9	2.9	2.9	2.9	2.9
	80 [26.7]	Total BTUH [kW]	59.9 [17.55]	58.8 [17.23]	57.7 [16.91]	56.2 [16.47]	55.2 [16.18]	54.2 [15.88]	53.5 [15.68]	52.6 [15.42]	51.6 [15.12]
		Sens BTUH [kW]	33.7 [9.88]	32.2 [9.44]	30.7 [9.00]	40.5 [11.87]	38.7 [11.34]	36.9 [10.81]	43.3 [12.69]	41.4 [12.13]	39.4 [11.55]
		Power	3.1	3.1	3.1	3.1	3.1	3.1	3.1	3.1	3.1
	85 [29.4]	Total BTUH [kW]	58.2 [17.06]	57.1 [16.73]	56.1 [16.44]	54.5 [15.97]	53.5 [15.68]	52.6 [15.42]	51.8 [15.18]	50.9 [14.92]	49.9 [14.62]
		Sens BTUH [kW]	32.8 [9.61]	31.3 [9.17]	29.8 [8.73]	39.6 [11.61]	37.8 [11.08]	36.0 [10.55]	42.3 [12.40]	40.4 [11.84]	38.6 [11.31]
		Power	3.3	3.3	3.3	3.3	3.3	3.2	3.3	3.3	3.2
	90 [32.2]	Total BTUH [kW]	56.4 [16.53]	55.4 [16.24]	54.4 [15.94]	52.8 [15.47]	51.8 [15.18]	50.9 [14.92]	50.1 [14.68]	49.2 [14.42]	48.3 [14.16]
Sens BTUH [kW]		31.9 [9.35]	30.4 [8.91]	29.0 [8.50]	38.7 [11.34]	36.9 [10.81]	35.2 [10.32]	41.4 [12.13]	39.6 [11.61]	37.7 [11.05]	
Power		3.5	3.5	3.4	3.5	3.4	3.4	3.5	3.4	3.4	
95 [35]	Total BTUH [kW]	54.7 [16.03]	53.7 [15.74]	52.7 [15.44]	51.0 [14.95]	50.1 [14.68]	49.2 [14.42]	48.3 [14.16]	47.4 [13.89]	46.6 [13.66]	
	Sens BTUH [kW]	31.0 [9.09]	29.6 [8.67]	28.2 [8.26]	37.8 [11.08]	36.1 [10.58]	34.4 [10.08]	40.6 [11.90]	38.7 [11.34]	36.9 [10.81]	
	Power	3.7	3.6	3.6	3.7	3.6	3.6	3.6	3.6	3.6	
100 [37.8]	Total BTUH [kW]	52.9 [15.50]	51.9 [15.21]	51.0 [14.95]	49.2 [14.42]	48.3 [14.16]	47.5 [13.92]	46.5 [13.63]	45.7 [13.39]	44.8 [13.13]	
	Sens BTUH [kW]	30.1 [8.82]	28.8 [8.44]	27.4 [8.03]	36.9 [10.81]	35.3 [10.35]	33.6 [9.85]	39.7 [11.63]	37.9 [11.11]	36.1 [10.58]	
	Power	3.9	3.8	3.8	3.8	3.8	3.8	3.8	3.8	3.8	
105 [40.6]	Total BTUH [kW]	51.0 [14.95]	50.1 [14.68]	49.2 [14.42]	47.3 [13.86]	46.5 [13.63]	45.6 [13.36]	44.6 [13.07]	43.8 [12.84]	43.0 [12.60]	
	Sens BTUH [kW]	29.2 [8.56]	27.9 [8.18]	26.6 [7.80]	36.0 [10.55]	34.4 [10.08]	32.8 [9.61]	38.8 [11.37]	37.0 [10.84]	35.3 [10.35]	
	Power	4.0	4.0	4.0	4.0	4.0	3.9	4.0	4.0	3.9	
110 [43.3]	Total BTUH [kW]	49.0 [14.36]	48.1 [14.10]	47.2 [13.83]	45.3 [13.28]	44.5 [13.04]	43.7 [12.81]	42.6 [12.48]	41.9 [12.28]	41.1 [12.05]	
	Sens BTUH [kW]	28.2 [8.26]	27.0 [7.91]	25.7 [7.53]	35.0 [10.26]	33.5 [9.82]	31.9 [9.35]	37.8 [11.08]	36.1 [10.58]	34.4 [10.08]	
	Power	4.2	4.2	4.1	4.2	4.2	4.1	4.2	4.1	4.1	
115 [46.1]	Total BTUH [kW]	46.9 [13.75]	46.1 [13.51]	45.2 [13.25]	43.2 [12.66]	42.5 [12.46]	41.7 [12.22]	40.5 [11.87]	39.8 [11.66]	39.1 [11.46]	
	Sens BTUH [kW]	27.1 [7.94]	25.9 [7.59]	24.7 [7.24]	33.9 [9.94]	32.4 [9.50]	30.9 [9.06]	36.7 [10.76]	35.1 [10.29]	33.4 [9.79]	
	Power	4.4	4.4	4.3	4.4	4.3	4.3	4.4	4.3	4.3	

## GROSS SYSTEMS PERFORMANCE DATA—360

		ENTERING INDOOR AIR @ 80°F [26.7°C] dbE ①									
		wbE	71°F [21.7°C]			67°F [19.4°C]			63°F [17.2°C]		
			CFM [L/s]	2040 [963]	1850 [873]	1660 [783]	2040 [963]	1850 [873]	1660 [783]	2040 [963]	1850 [873]
		DR ①	.21	.20	.18	.21	.20	.18	.21	.20	.18
OUTDOOR DRY BULB TEMPERATURE °F [°C]	75 [23.9]	Total BTUH [kW]	73.6 [21.57]	72.3 [21.19]	71.0 [20.81]	68.5 [20.08]	67.3 [19.72]	66.1 [19.37]	65.9 [19.31]	64.7 [18.96]	63.5 [18.61]
		Sens BTUH [kW]	42.2 [12.37]	40.3 [11.81]	38.4 [11.25]	49.1 [14.39]	46.9 [13.75]	44.7 [13.10]	53.3 [15.62]	50.9 [14.92]	48.5 [14.21]
		Power	4.0	3.9	3.9	3.9	3.8	3.8	3.8	3.8	3.7
	80 [26.7]	Total BTUH [kW]	71.3 [20.90]	70.0 [20.51]	68.7 [20.13]	66.2 [19.40]	65.0 [19.05]	63.9 [18.73]	63.6 [18.64]	62.4 [18.29]	61.3 [17.97]
		Sens BTUH [kW]	40.7 [11.93]	38.9 [11.40]	37.1 [10.87]	47.7 [13.98]	45.5 [13.33]	43.4 [12.72]	51.8 [15.18]	49.5 [14.51]	47.2 [13.83]
		Power	4.2	4.1	4.1	4.1	4.0	4.0	4.0	4.0	3.9
	85 [29.4]	Total BTUH [kW]	69.3 [20.31]	68.1 [19.96]	66.8 [19.58]	64.2 [18.82]	63.1 [18.49]	61.9 [18.14]	61.6 [18.05]	60.5 [17.73]	59.4 [17.41]
		Sens BTUH [kW]	39.5 [11.58]	37.8 [11.08]	36.0 [10.55]	46.5 [13.63]	44.4 [13.01]	42.3 [12.40]	50.6 [14.83]	48.3 [14.16]	46.1 [13.51]
		Power	4.4	4.4	4.3	4.3	4.3	4.2	4.2	4.2	4.1
	90 [32.2]	Total BTUH [kW]	67.5 [19.78]	66.3 [19.43]	65.1 [19.08]	62.5 [18.32]	61.3 [17.97]	60.2 [17.64]	59.8 [17.53]	58.7 [17.20]	57.6 [16.88]
Sens BTUH [kW]		38.5 [11.28]	36.8 [10.79]	35.1 [10.29]	45.5 [13.33]	43.5 [12.75]	41.4 [12.13]	49.6 [14.54]	47.4 [13.89]	45.2 [13.25]	
Power		4.6	4.6	4.5	4.5	4.5	4.4	4.4	4.4	4.4	
95 [35]	Total BTUH [kW]	65.8 [19.28]	64.7 [18.96]	63.5 [18.61]	60.8 [17.82]	59.7 [17.50]	58.6 [17.17]	58.1 [17.03]	57.1 [16.73]	56.0 [16.41]	
	Sens BTUH [kW]	37.7 [11.05]	36.0 [10.55]	34.3 [10.05]	44.6 [13.07]	42.6 [12.48]	40.7 [11.93]	48.8 [14.30]	46.6 [13.66]	44.4 [13.01]	
	Power	4.8	4.8	4.7	4.7	4.7	4.6	4.6	4.6	4.6	
100 [37.8]	Total BTUH [kW]	64.2 [18.82]	63.0 [18.46]	61.9 [18.14]	59.1 [17.32]	58.0 [17.00]	57.0 [16.71]	56.4 [16.53]	55.4 [16.24]	54.4 [15.94]	
	Sens BTUH [kW]	36.9 [10.81]	35.3 [10.35]	33.6 [9.85]	43.9 [12.87]	41.9 [12.28]	39.9 [11.69]	48.0 [14.07]	45.8 [13.42]	43.7 [12.81]	
	Power	5.0	5.0	4.9	4.9	4.9	4.8	4.9	4.8	4.8	
105 [40.6]	Total BTUH [kW]	62.4 [18.29]	61.3 [17.97]	60.1 [17.61]	57.3 [16.79]	56.3 [16.50]	55.3 [16.21]	54.6 [16.00]	53.7 [15.74]	52.7 [15.44]	
	Sens BTUH [kW]	36.1 [10.58]	34.5 [10.11]	32.9 [9.64]	43.1 [12.63]	41.2 [12.07]	39.2 [11.49]	47.2 [13.83]	45.1 [13.22]	43.0 [12.60]	
	Power	5.2	5.2	5.2	5.1	5.1	5.1	5.1	5.0	5.0	
110 [43.3]	Total BTUH [kW]	60.4 [17.70]	59.3 [17.38]	58.2 [17.06]	55.3 [16.21]	54.3 [15.91]	53.4 [15.65]	52.7 [15.44]	51.7 [15.15]	50.8 [14.89]	
	Sens BTUH [kW]	35.3 [10.35]	33.7 [9.88]	32.2 [9.44]	42.3 [12.40]	40.4 [11.84]	38.5 [11.28]	46.4 [13.60]	44.3 [12.98]	42.2 [12.37]	
	Power	5.5	5.4	5.4	5.4	5.3	5.3	5.3	5.2	5.2	
115 [46.1]	Total BTUH [kW]	58.1 [17.03]	57.1 [16.73]	56.0 [16.41]	53.0 [15.53]	52.1 [15.27]	51.1 [14.98]	50.4 [14.77]	49.5 [14.51]	48.6 [14.24]	
	Sens BTUH [kW]	34.4 [10.08]	32.8 [9.61]	31.3 [9.17]	41.3 [12.10]	39.5 [11.58]	37.6 [11.02]	45.4 [13.31]	43.4 [12.72]	41.4 [12.13]	
	Power	5.7	5.6	5.6	5.6	5.5	5.5	5.5	5.4	5.4	

DR —Depression ratio  
dbE—Entering air dry bulb  
wbE—Entering air wet bulb

Total —Total capacity x 1000 BTUH  
Sens —Sensible capacity x 1000 BTUH  
Power—KW input

NOTES: ① When the entering air dry bulb is other than 80°F [27°C], adjust the sensible capacity from the table by adding  $[1.10 \times \text{CFM} \times (1 - \text{DR}) \times (\text{dbE} - 80)]$ .

[ ] Designates Metric Conversions

# SYSTEMS PERFORMANCE—TZGE-4 SERIES

## GROSS SYSTEMS PERFORMANCE DATA—424

		ENTERING INDOOR AIR @ 80°F [26.7°C] dbE ①									
wbE		71°F [21.7°C]			67°F [19.4°C]			63°F [17.2°C]			
CFM [L/s]		880 [415]	800 [378]	720 [340]	880 [415]	800 [378]	720 [340]	880 [415]	800 [378]	720 [340]	
DR ①		.19	.17	.15	.19	.17	.15	.19	.17	.15	
OUTDOOR DRY BULB TEMPERATURE °F [°C]	75 [23.9]	Total BTUH [kW] Sens BTUH [kW] Power	29.6 [8.67] 17.6 [5.16] 1.5	29.1 [8.53] 16.8 [4.92] 1.5	28.5 [8.35] 16.0 [4.69] 1.5	27.8 [8.15] 20.7 [6.07] 1.5	27.3 [8.00] 19.8 [5.80] 1.5	26.8 [7.85] 18.9 [5.54] 1.5	26.6 [7.80] 22.2 [6.51] 1.5	26.1 [7.65] 21.2 [6.21] 1.5	25.6 [7.50] 20.2 [5.92] 1.5
	80 [26.7]	Total BTUH [kW] Sens BTUH [kW] Power	29.0 [8.50] 17.3 [5.07] 1.6	28.5 [8.35] 16.5 [4.84] 1.6	28.0 [8.21] 15.7 [4.60] 1.6	27.2 [7.97] 20.4 [5.98] 1.6	26.7 [7.83] 19.5 [5.71] 1.6	26.3 [7.71] 18.5 [5.42] 1.6	26.0 [7.62] 21.9 [6.42] 1.6	25.5 [7.47] 20.9 [6.13] 1.6	25.1 [7.36] 19.9 [5.83] 1.6
	85 [29.4]	Total BTUH [kW] Sens BTUH [kW] Power	28.3 [8.29] 16.8 [4.92] 1.7	27.8 [8.15] 16.1 [4.72] 1.7	27.3 [8.00] 15.3 [4.48] 1.7	26.5 [7.77] 19.9 [5.83] 1.7	26.0 [7.62] 19.1 [5.60] 1.7	25.6 [7.50] 18.2 [5.33] 1.7	25.3 [7.41] 21.4 [6.27] 1.7	24.8 [7.27] 20.5 [6.01] 1.7	24.4 [7.15] 19.5 [5.71] 1.7
	90 [32.2]	Total BTUH [kW] Sens BTUH [kW] Power	27.5 [8.06] 16.4 [4.81] 1.8	27.0 [7.91] 15.6 [4.57] 1.8	26.5 [7.77] 14.9 [4.37] 1.8	25.7 [7.53] 19.5 [5.71] 1.8	25.2 [7.39] 18.6 [5.45] 1.8	24.8 [7.27] 17.7 [5.19] 1.8	24.5 [7.18] 21.0 [6.15] 1.8	24.0 [7.03] 20.0 [5.86] 1.8	23.6 [6.92] 19.1 [5.60] 1.8
	95 [35]	Total BTUH [kW] Sens BTUH [kW] Power	26.6 [7.80] 15.9 [4.66] 1.9	26.1 [7.65] 15.2 [4.45] 1.9	25.7 [7.53] 14.5 [4.25] 1.9	24.8 [7.27] 19.0 [5.57] 1.9	24.4 [7.15] 18.2 [5.33] 1.9	23.9 [7.00] 17.3 [5.07] 1.9	23.6 [6.92] 20.5 [6.01] 1.9	23.2 [6.80] 19.6 [5.74] 1.9	22.8 [6.68] 18.7 [5.48] 1.9
	100 [37.8]	Total BTUH [kW] Sens BTUH [kW] Power	25.7 [7.53] 15.5 [4.54] 2.0	25.2 [7.39] 14.8 [4.34] 2.0	24.8 [7.27] 14.1 [4.13] 2.0	23.9 [7.00] 18.6 [5.45] 2.0	23.5 [6.89] 17.7 [5.19] 2.0	23.1 [6.77] 16.9 [4.95] 2.0	22.7 [6.65] 20.1 [5.89] 2.0	22.3 [6.54] 19.2 [5.63] 2.0	21.9 [6.42] 18.3 [5.36] 2.0
	105 [40.6]	Total BTUH [kW] Sens BTUH [kW] Power	24.8 [7.27] 15.1 [4.43] 2.1	24.4 [7.15] 14.4 [4.22] 2.1	23.9 [7.00] 13.7 [4.02] 2.1	23.0 [6.74] 18.2 [5.33] 2.1	22.6 [6.62] 17.4 [5.10] 2.1	22.2 [6.51] 16.6 [4.86] 2.1	21.8 [6.39] 19.7 [5.77] 2.1	21.4 [6.27] 18.8 [5.51] 2.1	21.0 [6.15] 17.9 [5.25] 2.1
	110 [43.3]	Total BTUH [kW] Sens BTUH [kW] Power	24.0 [7.03] 14.8 [4.34] 2.2	23.5 [6.89] 14.2 [4.16] 2.2	23.1 [6.77] 13.5 [3.96] 2.2	22.2 [6.51] 17.9 [5.25] 2.2	21.8 [6.39] 17.1 [5.01] 2.2	21.4 [6.27] 16.3 [4.78] 2.2	21.0 [6.15] 19.4 [5.69] 2.2	20.6 [6.04] 18.6 [5.45] 2.2	20.2 [5.92] 17.7 [5.19] 2.2
	115 [46.1]	Total BTUH [kW] Sens BTUH [kW] Power	23.2 [6.80] 14.7 [4.31] 2.3	22.8 [6.68] 14.0 [4.10] 2.3	22.4 [6.56] 13.4 [3.93] 2.2	21.4 [6.27] 17.8 [5.22] 2.3	21.0 [6.15] 17.0 [4.98] 2.3	20.7 [6.07] 16.2 [4.75] 2.2	20.2 [5.92] 19.3 [5.66] 2.3	19.8 [5.80] 18.4 [5.39] 2.3	19.5 [5.71] 17.6 [5.16] 2.2

## GROSS SYSTEMS PERFORMANCE DATA—430

		ENTERING INDOOR AIR @ 80°F [26.7°C] dbE ①									
wbE		71°F [21.7°C]			67°F [19.4°C]			63°F [17.2°C]			
CFM [L/s]		1100 [519]	1000 [472]	900 [425]	1100 [519]	1000 [472]	900 [425]	1100 [519]	1000 [472]	900 [425]	
DR ①		.20	.19	.17	.20	.19	.17	.20	.19	.17	
OUTDOOR DRY BULB TEMPERATURE °F [°C]	75 [23.9]	Total BTUH [kW] Sens BTUH [kW] Power	36.7 [10.76] 21.5 [6.30] 1.8	36.1 [10.58] 20.6 [6.04] 1.8	35.4 [10.37] 19.6 [5.74] 1.8	34.5 [10.11] 25.7 [7.53] 1.8	33.9 [9.94] 24.6 [7.21] 1.8	33.3 [9.76] 23.4 [6.86] 1.8	33.1 [9.70] 27.4 [8.03] 1.8	32.5 [9.52] 26.2 [7.68] 1.8	32.0 [9.38] 25.0 [7.33] 1.8
	80 [26.7]	Total BTUH [kW] Sens BTUH [kW] Power	35.8 [10.49] 20.9 [6.13] 1.9	35.2 [10.32] 20.0 [5.86] 1.9	34.5 [10.11] 19.0 [5.57] 1.9	33.6 [9.85] 25.1 [7.36] 1.9	33.0 [9.67] 24.0 [7.03] 1.9	32.4 [9.50] 22.9 [6.71] 1.9	32.2 [9.44] 26.8 [7.85] 1.9	31.6 [9.26] 25.6 [7.50] 1.9	31.1 [9.11] 24.4 [7.15] 1.9
	85 [29.4]	Total BTUH [kW] Sens BTUH [kW] Power	34.8 [10.20] 20.3 [5.95] 2.0	34.2 [10.02] 19.4 [5.69] 2.0	33.5 [9.82] 18.5 [5.42] 2.0	32.6 [9.55] 24.5 [7.18] 2.0	32.0 [9.38] 23.4 [6.86] 2.0	31.4 [9.20] 22.3 [6.54] 2.0	31.2 [9.14] 26.1 [7.65] 2.0	30.6 [8.97] 25.0 [7.33] 2.0	30.1 [8.82] 23.8 [6.98] 2.0
	90 [32.2]	Total BTUH [kW] Sens BTUH [kW] Power	33.7 [9.88] 19.7 [5.77] 2.1	33.1 [9.70] 18.8 [5.51] 2.1	32.5 [9.52] 17.9 [5.25] 2.1	31.4 [9.20] 23.8 [6.98] 2.1	30.9 [9.06] 22.8 [6.68] 2.1	30.3 [8.88] 21.7 [6.36] 2.1	30.1 [8.82] 25.5 [7.47] 2.1	29.5 [8.65] 24.4 [7.15] 2.1	29.0 [8.50] 23.3 [6.83] 2.1
	95 [35]	Total BTUH [kW] Sens BTUH [kW] Power	32.4 [9.50] 19.0 [5.57] 2.3	31.9 [9.35] 18.2 [5.33] 2.2	31.3 [9.17] 17.3 [5.07] 2.2	30.2 [8.85] 23.2 [6.80] 2.3	29.7 [8.70] 22.2 [6.51] 2.2	29.1 [8.53] 21.1 [6.18] 2.2	28.9 [8.47] 24.9 [7.30] 2.2	28.3 [8.29] 23.8 [6.98] 2.2	27.8 [8.15] 22.7 [6.65] 2.2
	100 [37.8]	Total BTUH [kW] Sens BTUH [kW] Power	31.2 [9.14] 18.4 [5.39] 2.4	30.6 [8.97] 17.6 [5.16] 2.3	30.1 [8.82] 16.7 [4.89] 2.3	28.9 [8.47] 22.6 [6.62] 2.4	28.4 [8.32] 21.6 [6.33] 2.3	27.9 [8.18] 20.5 [6.01] 2.3	27.6 [8.09] 24.2 [7.09] 2.4	27.1 [7.94] 23.2 [6.80] 2.3	26.6 [7.80] 22.1 [6.48] 2.3
	105 [40.6]	Total BTUH [kW] Sens BTUH [kW] Power	29.8 [8.73] 17.7 [5.19] 2.5	29.3 [8.59] 16.9 [4.95] 2.5	28.8 [8.44] 16.1 [4.72] 2.4	27.6 [8.09] 21.9 [6.42] 2.5	27.1 [7.94] 20.9 [6.13] 2.5	26.6 [7.80] 19.9 [5.83] 2.4	26.2 [7.68] 23.5 [6.89] 2.5	25.8 [7.56] 22.5 [6.59] 2.4	25.3 [7.41] 21.4 [6.27] 2.4
	110 [43.3]	Total BTUH [kW] Sens BTUH [kW] Power	28.5 [8.35] 16.9 [4.95] 2.6	27.9 [8.18] 16.2 [4.75] 2.6	27.4 [8.03] 15.4 [4.51] 2.5	26.2 [7.68] 21.1 [6.18] 2.6	25.8 [7.56] 20.2 [5.92] 2.6	25.3 [7.41] 19.2 [5.63] 2.5	24.9 [7.30] 22.8 [6.68] 2.6	24.4 [7.15] 21.8 [6.39] 2.6	24.0 [7.03] 20.8 [6.10] 2.5
	115 [46.1]	Total BTUH [kW] Sens BTUH [kW] Power	27.1 [7.94] 16.2 [4.75] 2.7	26.6 [7.80] 15.4 [4.51] 2.7	26.1 [7.65] 14.7 [4.31] 2.6	24.8 [7.27] 20.3 [5.95] 2.7	24.4 [7.15] 19.4 [5.69] 2.7	23.9 [7.00] 18.5 [5.42] 2.6	23.5 [6.89] 22.0 [6.45] 2.7	23.0 [6.74] 21.0 [6.15] 2.7	22.6 [6.62] 20.1 [5.89] 2.6

DR —Depression ratio  
dbE—Entering air dry bulb  
wbE—Entering air wet bulb

Total —Total capacity x 1000 BTUH  
Sens —Sensible capacity x 1000 BTUH  
Power—kW input

NOTES: ① When the entering air dry bulb is other than 80°F [27°C], adjust the sensible capacity from the table by adding [1.10 x CFM x (1 - DR) x (dbE - 80)].

[ ] Designates Metric Conversions

# SYSTEMS PERFORMANCE—TZGE-4 SERIES

## GROSS SYSTEMS PERFORMANCE DATA—436

		ENTERING INDOOR AIR @ 80°F [26.7°C] dbE ①									
		wbE	71°F [21.7°C]			67°F [19.4°C]			63°F [17.2°C]		
		CFM [L/s]	1320 [623]	1200 [566]	1080 [510]	1320 [623]	1200 [566]	1080 [510]	1320 [623]	1200 [566]	1080 [510]
		DR ①	.19	.18	.16	.19	.18	.16	.19	.18	.16
OUTDOOR DRY BULB TEMPERATURE °F [°C]	75 [23.9]	Total BTUH [kW]	44.7 [13.10]	43.9 [12.87]	43.1 [12.63]	42.1 [12.34]	41.3 [12.10]	40.6 [11.90]	40.4 [11.84]	39.7 [11.63]	39.0 [11.43]
		Sens BTUH [kW]	25.8 [7.56]	24.7 [7.24]	23.5 [6.89]	31.0 [9.09]	29.6 [8.67]	28.2 [8.26]	32.9 [9.64]	31.5 [9.23]	30.0 [8.79]
		Power	2.2	2.2	2.2	2.2	2.2	2.2	2.2	2.2	2.1
	80 [26.7]	Total BTUH [kW]	44.0 [12.90]	43.3 [12.69]	42.5 [12.46]	41.4 [12.13]	40.6 [11.90]	39.9 [11.69]	39.7 [11.63]	39.0 [11.43]	38.3 [11.22]
		Sens BTUH [kW]	25.5 [7.47]	24.3 [7.12]	23.2 [6.80]	30.7 [9.00]	29.3 [8.59]	27.9 [8.18]	32.6 [9.55]	31.1 [9.11]	29.7 [8.70]
		Power	2.3	2.3	2.3	2.3	2.3	2.3	2.3	2.3	2.3
	85 [29.4]	Total BTUH [kW]	43.0 [12.60]	42.2 [12.37]	41.4 [12.13]	40.3 [11.81]	39.6 [11.61]	38.9 [11.40]	38.6 [11.31]	38.0 [11.14]	37.3 [10.93]
		Sens BTUH [kW]	24.9 [7.30]	23.8 [6.98]	22.7 [6.65]	30.1 [8.82]	28.7 [8.41]	27.4 [8.03]	32.0 [9.38]	30.6 [8.97]	29.1 [8.53]
		Power	2.5	2.5	2.4	2.5	2.4	2.4	2.5	2.4	2.4
	90 [32.2]	Total BTUH [kW]	41.6 [12.19]	40.9 [11.99]	40.1 [11.75]	39.0 [11.43]	38.3 [11.22]	37.6 [11.02]	37.3 [10.93]	36.6 [10.73]	36.0 [10.55]
	Sens BTUH [kW]	24.1 [7.06]	23.1 [6.77]	22.0 [6.45]	29.3 [8.59]	28.0 [8.21]	26.7 [7.83]	31.2 [9.14]	29.9 [8.76]	28.5 [8.35]	
	Power	2.6	2.6	2.6	2.6	2.6	2.6	2.6	2.6	2.5	
95 [35]	Total BTUH [kW]	40.1 [11.75]	39.4 [11.55]	38.7 [11.34]	37.5 [10.99]	36.8 [10.79]	36.1 [10.58]	35.8 [10.49]	35.2 [10.32]	34.5 [10.11]	
	Sens BTUH [kW]	23.3 [6.83]	22.3 [6.54]	21.2 [6.21]	28.5 [8.35]	27.2 [7.97]	25.9 [7.59]	30.4 [8.91]	29.1 [8.53]	27.7 [8.12]	
	Power	2.7	2.7	2.7	2.7	2.7	2.7	2.7	2.7	2.7	
100 [37.8]	Total BTUH [kW]	38.5 [11.28]	37.8 [11.08]	37.1 [10.87]	35.9 [10.52]	35.2 [10.32]	34.6 [10.14]	34.2 [10.02]	33.6 [9.85]	33.0 [9.67]	
	Sens BTUH [kW]	22.4 [6.56]	21.4 [6.27]	20.4 [5.98]	27.6 [8.09]	26.4 [7.74]	25.2 [7.39]	29.6 [8.67]	28.2 [8.26]	26.9 [7.88]	
	Power	2.9	2.9	2.8	2.9	2.8	2.8	2.9	2.8	2.8	
105 [40.6]	Total BTUH [kW]	36.9 [10.81]	36.3 [10.64]	35.6 [10.43]	34.3 [10.05]	33.7 [9.88]	33.0 [9.67]	32.6 [9.55]	32.0 [9.38]	31.4 [9.20]	
	Sens BTUH [kW]	21.6 [6.33]	20.7 [6.07]	19.7 [5.77]	26.8 [7.85]	25.6 [7.50]	24.4 [7.15]	28.8 [8.44]	27.5 [8.06]	26.2 [7.68]	
	Power	3.0	3.0	3.0	3.0	3.0	3.0	3.0	3.0	2.9	
110 [43.3]	Total BTUH [kW]	35.5 [10.40]	34.8 [10.20]	34.2 [10.02]	32.8 [9.61]	32.2 [9.44]	31.6 [9.26]	31.1 [9.11]	30.6 [8.97]	30.0 [8.79]	
	Sens BTUH [kW]	21.0 [6.15]	20.1 [5.89]	19.1 [5.60]	26.2 [7.68]	25.0 [7.33]	23.8 [6.98]	28.1 [8.24]	26.9 [7.88]	25.6 [7.50]	
	Power	3.2	3.1	3.1	3.1	3.1	3.1	3.1	3.1	3.1	
115 [46.1]	Total BTUH [kW]	34.2 [10.02]	33.6 [9.85]	33.0 [9.67]	31.5 [9.23]	31.0 [9.09]	30.4 [8.91]	29.9 [8.76]	29.3 [8.59]	28.8 [8.44]	
	Sens BTUH [kW]	20.6 [6.04]	19.6 [5.74]	18.7 [5.48]	25.7 [7.53]	24.6 [7.21]	23.4 [6.86]	27.7 [8.12]	26.4 [7.74]	25.2 [7.39]	
	Power	3.3	3.3	3.2	3.3	3.2	3.2	3.3	3.2	3.2	

## GROSS SYSTEMS PERFORMANCE DATA—442

		ENTERING INDOOR AIR @ 80°F [26.7°C] dbE ①									
		wbE	71°F [21.7°C]			67°F [19.4°C]			63°F [17.2°C]		
		CFM [L/s]	1540 [727]	1400 [661]	1260 [595]	1540 [727]	1400 [661]	1260 [595]	1540 [727]	1400 [661]	1260 [595]
		DR ①	.19	.17	.16	.19	.17	.16	.19	.17	.16
OUTDOOR DRY BULB TEMPERATURE °F [°C]	75 [23.9]	Total BTUH [kW]	54.0 [15.83]	53.0 [15.53]	52.1 [15.27]	50.6 [14.83]	49.7 [14.57]	48.8 [14.30]	48.9 [14.33]	48.0 [14.07]	47.2 [13.83]
		Sens BTUH [kW]	31.1 [9.11]	29.7 [8.70]	28.3 [8.29]	36.6 [10.73]	35.0 [10.26]	33.4 [9.79]	39.8 [11.66]	38.1 [11.17]	36.3 [10.64]
		Power	2.7	2.7	2.6	2.7	2.6	2.6	2.7	2.6	2.6
	80 [26.7]	Total BTUH [kW]	52.4 [15.36]	51.5 [15.09]	50.6 [14.83]	49.0 [14.36]	48.2 [14.13]	47.3 [13.86]	47.3 [13.86]	46.5 [13.63]	45.7 [13.39]
		Sens BTUH [kW]	30.4 [8.91]	29.0 [8.50]	27.7 [8.12]	35.9 [10.52]	34.3 [10.05]	32.7 [9.58]	39.1 [11.46]	37.4 [10.96]	35.6 [10.43]
		Power	2.8	2.8	2.8	2.8	2.8	2.8	2.8	2.8	2.8
	85 [29.4]	Total BTUH [kW]	51.0 [14.95]	50.1 [14.68]	49.2 [14.42]	47.6 [13.95]	46.7 [13.69]	45.9 [13.45]	45.9 [13.45]	45.1 [13.22]	44.2 [12.95]
		Sens BTUH [kW]	29.7 [8.70]	28.3 [8.29]	27.0 [7.91]	35.2 [10.32]	33.6 [9.85]	32.1 [9.41]	38.4 [11.25]	36.7 [10.76]	35.0 [10.26]
		Power	3.0	3.0	2.9	3.0	2.9	2.9	3.0	2.9	2.9
	90 [32.2]	Total BTUH [kW]	49.6 [14.54]	48.7 [14.27]	47.8 [14.01]	46.2 [13.54]	45.4 [13.31]	44.5 [13.04]	44.5 [13.04]	43.7 [12.81]	42.9 [12.57]
	Sens BTUH [kW]	29.0 [8.50]	27.7 [8.12]	26.4 [7.74]	34.5 [10.11]	33.0 [9.67]	31.4 [9.20]	37.7 [11.05]	36.0 [10.55]	34.3 [10.05]	
	Power	3.1	3.1	3.1	3.1	3.1	3.1	3.1	3.1	3.1	
95 [35]	Total BTUH [kW]	48.2 [14.13]	47.4 [13.89]	46.5 [13.63]	44.8 [13.13]	44.0 [12.90]	43.2 [12.66]	43.1 [12.63]	42.4 [12.43]	41.6 [12.19]	
	Sens BTUH [kW]	28.3 [8.29]	27.0 [7.91]	25.7 [7.53]	33.8 [9.91]	32.3 [9.47]	30.8 [9.03]	37.0 [10.84]	35.3 [10.35]	33.7 [9.88]	
	Power	3.3	3.3	3.2	3.3	3.2	3.2	3.3	3.2	3.2	
100 [37.8]	Total BTUH [kW]	46.9 [13.75]	46.0 [13.48]	45.2 [13.25]	43.5 [12.75]	42.7 [12.51]	41.9 [12.28]	41.8 [12.25]	41.0 [12.02]	40.3 [11.81]	
	Sens BTUH [kW]	27.5 [8.06]	26.3 [7.71]	25.1 [7.36]	33.1 [9.70]	31.6 [9.26]	30.1 [8.82]	36.3 [10.64]	34.7 [10.17]	33.0 [9.67]	
	Power	3.4	3.4	3.4	3.4	3.4	3.4	3.4	3.4	3.4	
105 [40.6]	Total BTUH [kW]	45.5 [13.33]	44.7 [13.10]	43.9 [12.87]	42.1 [12.34]	41.4 [12.13]	40.6 [11.90]	40.4 [11.84]	39.7 [11.63]	39.0 [11.43]	
	Sens BTUH [kW]	26.8 [7.85]	25.6 [7.50]	24.4 [7.15]	32.3 [9.47]	30.9 [9.06]	29.4 [8.62]	35.5 [10.40]	33.9 [9.94]	32.3 [9.47]	
	Power	3.6	3.6	3.5	3.6	3.5	3.5	3.6	3.5	3.5	
110 [43.3]	Total BTUH [kW]	44.1 [12.92]	43.3 [12.69]	42.5 [12.46]	40.7 [11.93]	40.0 [11.72]	39.3 [11.52]	39.0 [11.43]	38.3 [11.22]	37.6 [11.02]	
	Sens BTUH [kW]	26.0 [7.62]	24.8 [7.27]	23.7 [6.95]	31.5 [9.23]	30.1 [8.82]	28.7 [8.41]	34.7 [10.17]	33.2 [9.73]	31.6 [9.26]	
	Power	3.7	3.7	3.7	3.7	3.7	3.7	3.7	3.7	3.7	
115 [46.1]	Total BTUH [kW]	42.7 [12.51]	41.9 [12.28]	41.1 [12.05]	39.3 [11.52]	38.6 [11.31]	37.9 [11.11]	37.6 [11.02]	36.9 [10.81]	36.2 [10.61]	
	Sens BTUH [kW]	25.1 [7.36]	24.0 [7.03]	22.9 [6.71]	30.7 [9.00]	29.3 [8.59]	27.9 [8.18]	33.8 [9.91]	32.3 [9.47]	30.8 [9.03]	
	Power	3.9	3.9	3.8	3.9	3.8	3.8	3.9	3.8	3.8	

DR —Depression ratio  
dbE—Entering air dry bulb  
wbE—Entering air wet bulb

Total —Total capacity x 1000 BTUH  
Sens —Sensible capacity x 1000 BTUH  
Power—KW input

NOTES: ① When the entering air dry bulb is other than 80°F [27°C], adjust the sensible capacity from the table by adding  $[1.10 \times \text{CFM} \times (1 - \text{DR}) \times (\text{dbE} - 80)]$ .

[ ] Designates Metric Conversions



# SYSTEMS PERFORMANCE—TZGE-4 SERIES

## GROSS SYSTEMS PERFORMANCE DATA—348

		ENTERING INDOOR AIR @ 80°F [26.7°C] dbE ①									
		wbE	71°F [21.7°C]			67°F [19.4°C]			63°F [17.2°C]		
		CFM [L/s]	1760 [831]	1600 [755]	1440 [680]	1760 [831]	1600 [755]	1440 [680]	1760 [831]	1600 [755]	1440 [680]
		DR ①	.21	.20	.18	.21	.20	.18	.21	.20	.18
OUTDOOR DRY BULB TEMPERATURE °F [°C]	75 [23.9]	Total BTUH [kW] Sens BTUH [kW] Power	62.0 [18.17] 35.0 [10.26] 3.0	60.9 [17.85] 33.4 [9.79] 3.0	59.8 [17.53] 31.9 [9.35] 3.0	58.3 [17.09] 41.9 [12.28] 3.0	57.3 [16.79] 40.0 [11.72] 3.0	56.3 [16.50] 38.1 [11.17] 2.9	55.6 [16.29] 44.7 [13.10] 3.0	54.6 [16.00] 42.7 [12.51] 3.0	53.6 [15.71] 40.7 [11.93] 2.9
	80 [26.7]	Total BTUH [kW] Sens BTUH [kW] Power	60.3 [17.67] 33.9 [9.94] 3.2	59.2 [17.35] 32.4 [9.50] 3.2	58.1 [17.03] 30.9 [9.06] 3.1	56.6 [16.59] 40.8 [11.96] 3.2	55.5 [16.27] 39.0 [11.43] 3.1	54.5 [15.97] 37.2 [10.90] 3.1	53.8 [15.77] 43.6 [12.78] 3.2	52.8 [15.47] 41.7 [12.22] 3.1	51.9 [15.21] 39.7 [11.63] 3.1
	85 [29.4]	Total BTUH [kW] Sens BTUH [kW] Power	58.5 [17.14] 32.9 [9.64] 3.4	57.5 [16.85] 31.5 [9.23] 3.3	56.4 [16.53] 30.0 [8.79] 3.3	54.8 [16.06] 39.8 [11.66] 3.3	53.8 [15.77] 38.1 [11.17] 3.3	52.8 [15.47] 36.3 [10.64] 3.3	52.0 [15.24] 42.6 [12.48] 3.3	51.1 [14.98] 40.7 [11.93] 3.3	50.2 [14.71] 38.8 [11.37] 3.3
	90 [32.2]	Total BTUH [kW] Sens BTUH [kW] Power	56.7 [16.62] 32.0 [9.38] 3.5	55.7 [16.32] 30.6 [8.97] 3.5	54.7 [16.03] 29.2 [8.56] 3.5	53.0 [15.53] 38.9 [11.40] 3.5	52.1 [15.27] 37.2 [10.90] 3.5	51.1 [14.98] 35.4 [10.37] 3.4	50.3 [14.74] 41.7 [12.22] 3.5	49.4 [14.48] 39.9 [11.69] 3.5	48.5 [14.21] 38.0 [11.14] 3.4
	95 [35]	Total BTUH [kW] Sens BTUH [kW] Power	55.0 [16.12] 31.1 [9.11] 3.7	54.0 [15.83] 29.7 [8.70] 3.7	53.0 [15.53] 28.3 [8.29] 3.6	51.3 [15.03] 38.0 [11.14] 3.7	50.3 [14.74] 36.3 [10.64] 3.6	49.4 [14.48] 34.6 [10.14] 3.6	48.5 [14.21] 40.8 [11.96] 3.7	47.6 [13.95] 39.0 [11.43] 3.6	46.8 [13.72] 37.2 [10.90] 3.6
	100 [37.8]	Total BTUH [kW] Sens BTUH [kW] Power	53.1 [15.56] 30.2 [8.85] 3.9	52.2 [15.30] 28.9 [8.47] 3.8	51.2 [15.01] 27.5 [8.06] 3.8	49.4 [14.48] 37.1 [10.87] 3.8	48.5 [14.21] 35.5 [10.40] 3.8	47.7 [13.98] 33.8 [9.91] 3.8	46.7 [13.69] 40.0 [11.72] 3.8	45.8 [13.42] 38.2 [11.20] 3.8	45.0 [13.19] 36.4 [10.67] 3.8
	105 [40.6]	Total BTUH [kW] Sens BTUH [kW] Power	51.2 [15.01] 29.3 [8.59] 4.0	50.3 [14.74] 28.0 [8.21] 4.0	49.4 [14.48] 26.7 [7.83] 4.0	47.5 [13.92] 36.2 [10.61] 4.0	46.7 [13.69] 34.6 [10.14] 4.0	45.8 [13.42] 33.0 [9.67] 3.9	44.8 [13.13] 39.0 [11.43] 4.0	44.0 [12.90] 37.3 [10.93] 4.0	43.2 [12.66] 35.5 [10.40] 3.9
	110 [43.3]	Total BTUH [kW] Sens BTUH [kW] Power	49.2 [14.42] 28.3 [8.29] 4.2	48.3 [14.16] 27.1 [7.94] 4.2	47.5 [13.92] 25.8 [7.56] 4.1	45.5 [13.33] 35.2 [10.32] 4.2	44.7 [13.10] 33.6 [9.85] 4.1	43.9 [12.87] 32.1 [9.41] 4.1	42.8 [12.54] 38.0 [11.14] 4.2	42.0 [12.31] 36.3 [10.64] 4.1	41.2 [12.07] 34.6 [10.14] 4.1
	115 [46.1]	Total BTUH [kW] Sens BTUH [kW] Power	47.1 [13.80] 27.2 [7.97] 4.4	46.2 [13.54] 26.0 [7.62] 4.3	45.4 [13.31] 24.8 [7.27] 4.3	43.4 [12.72] 34.1 [9.99] 4.3	42.6 [12.48] 32.6 [9.55] 4.3	41.8 [12.25] 31.1 [9.11] 4.3	40.6 [11.90] 36.9 [10.81] 4.3	39.9 [11.69] 35.3 [10.35] 4.3	39.2 [11.49] 33.6 [9.85] 4.3

## GROSS SYSTEMS PERFORMANCE DATA—360

		ENTERING INDOOR AIR @ 80°F [26.7°C] dbE ①									
		wbE	71°F [21.7°C]			67°F [19.4°C]			63°F [17.2°C]		
		CFM [L/s]	2040 [963]	1850 [873]	1660 [783]	2040 [963]	1850 [873]	1660 [783]	2040 [963]	1850 [873]	1660 [783]
		DR ①	.21	.20	.18	.21	.20	.18	.21	.20	.18
OUTDOOR DRY BULB TEMPERATURE °F [°C]	75 [23.9]	Total BTUH [kW] Sens BTUH [kW] Power	73.6 [21.57] 42.2 [12.37] 4.0	72.3 [21.19] 40.3 [11.81] 3.9	71.0 [20.81] 38.4 [11.25] 3.9	68.5 [20.08] 49.1 [14.39] 3.9	67.3 [19.72] 46.9 [13.75] 3.8	66.1 [19.37] 44.7 [13.10] 3.8	65.9 [19.31] 53.3 [15.62] 3.8	64.7 [18.96] 50.9 [14.92] 3.8	63.5 [18.61] 48.5 [14.21] 3.7
	80 [26.7]	Total BTUH [kW] Sens BTUH [kW] Power	71.3 [20.90] 40.7 [11.93] 4.2	70.0 [20.51] 38.9 [11.40] 4.1	68.7 [20.13] 37.1 [10.87] 4.1	66.2 [19.40] 47.7 [13.98] 4.1	65.0 [19.05] 45.5 [13.33] 4.0	63.9 [18.73] 43.4 [12.72] 4.0	63.6 [18.64] 51.8 [15.18] 4.0	62.4 [18.29] 49.5 [14.51] 4.0	61.3 [17.97] 47.2 [13.83] 3.9
	85 [29.4]	Total BTUH [kW] Sens BTUH [kW] Power	69.3 [20.31] 39.5 [11.58] 4.4	68.1 [19.96] 37.8 [11.08] 4.4	66.8 [19.58] 36.0 [10.55] 4.3	64.2 [18.82] 46.5 [13.63] 4.3	63.1 [18.49] 44.4 [13.01] 4.3	61.9 [18.14] 42.3 [12.40] 4.2	61.6 [18.05] 50.6 [14.83] 4.2	60.5 [17.73] 48.3 [14.16] 4.2	59.4 [17.41] 46.1 [13.51] 4.1
	90 [32.2]	Total BTUH [kW] Sens BTUH [kW] Power	67.5 [19.78] 38.5 [11.28] 4.6	66.3 [19.43] 36.8 [10.79] 4.6	65.1 [19.08] 35.1 [10.29] 4.5	62.5 [18.32] 45.5 [13.33] 4.5	61.3 [17.97] 43.5 [12.75] 4.5	60.2 [17.64] 41.4 [12.13] 4.4	59.8 [17.53] 49.6 [14.54] 4.4	58.7 [17.20] 47.4 [13.89] 4.4	57.6 [16.88] 45.2 [13.25] 4.4
	95 [35]	Total BTUH [kW] Sens BTUH [kW] Power	65.8 [19.28] 37.7 [11.05] 4.8	64.7 [18.96] 36.0 [10.55] 4.8	63.5 [18.61] 34.3 [10.05] 4.7	60.8 [17.82] 44.6 [13.07] 4.7	59.7 [17.50] 42.6 [12.48] 4.7	58.6 [17.17] 40.7 [11.93] 4.6	58.1 [17.03] 48.8 [14.30] 4.6	57.1 [16.73] 46.6 [13.66] 4.6	56.0 [16.41] 44.4 [13.01] 4.6
	100 [37.8]	Total BTUH [kW] Sens BTUH [kW] Power	64.2 [18.82] 36.9 [10.81] 5.0	63.0 [18.46] 35.3 [10.35] 5.0	61.9 [18.14] 33.6 [9.85] 4.9	59.1 [17.32] 43.9 [12.87] 4.9	58.0 [17.00] 41.9 [12.28] 4.9	57.0 [16.71] 39.9 [11.69] 4.8	56.4 [16.53] 48.0 [14.07] 4.9	55.4 [16.24] 45.8 [13.42] 4.8	54.4 [15.94] 43.7 [12.81] 4.8
	105 [40.6]	Total BTUH [kW] Sens BTUH [kW] Power	62.4 [18.29] 36.1 [10.58] 5.2	61.3 [17.97] 34.5 [10.11] 5.2	60.1 [17.61] 32.9 [9.64] 5.2	57.3 [16.79] 43.1 [12.63] 5.1	56.3 [16.50] 41.2 [12.07] 5.1	55.3 [16.21] 39.2 [11.49] 5.1	54.6 [16.00] 47.2 [13.83] 5.1	53.7 [15.74] 45.1 [13.22] 5.0	52.7 [15.44] 43.0 [12.60] 5.0
	110 [43.3]	Total BTUH [kW] Sens BTUH [kW] Power	60.4 [17.70] 35.3 [10.35] 5.5	59.3 [17.38] 33.7 [9.88] 5.4	58.2 [17.06] 32.2 [9.44] 5.4	55.3 [16.21] 42.3 [12.40] 5.4	54.3 [15.91] 40.4 [11.84] 5.3	53.4 [15.65] 38.5 [11.28] 5.3	52.7 [15.44] 46.4 [13.60] 5.3	51.7 [15.15] 44.3 [12.98] 5.2	50.8 [14.89] 42.2 [12.37] 5.2
	115 [46.1]	Total BTUH [kW] Sens BTUH [kW] Power	58.1 [17.03] 34.4 [10.08] 5.7	57.1 [16.73] 32.8 [9.61] 5.6	56.0 [16.41] 31.3 [9.17] 5.6	53.0 [15.53] 41.3 [12.10] 5.6	52.1 [15.27] 39.5 [11.58] 5.5	51.1 [14.98] 37.6 [11.02] 5.5	50.4 [14.77] 45.4 [13.31] 5.5	49.5 [14.51] 43.4 [12.72] 5.4	48.6 [14.24] 41.4 [12.13] 5.4

DR —Depression ratio  
dbE—Entering air dry bulb  
wbE—Entering air wet bulb

Total —Total capacity x 1000 BTUH  
Sens —Sensible capacity x 1000 BTUH  
Power—KW input

NOTES: ① When the entering air dry bulb is other than 80°F [27°C], adjust the sensible capacity from the table by adding  $[1.10 \times \text{CFM} \times (1 - \text{DR}) \times (\text{dbE} - 80)]$ .

[ ] Designates Metric Conversions

## INDOOR AIRFLOW PERFORMANCE—208 VOLTS

Nominal Cooling Capacity Tons [kW]	Motor Speed from Factory		Heating Input BTU/HR [kW]	Blower Size/ Motor HP [W] & # of Speeds	Motor Speed	External Static Pressure—Inches W.C. [kPa] Side Discharge—Wet Coil						
	Cool	Heat				0.1 [0.02]	0.2 [0.05]	0.3 [0.07]	0.4 [0.10]	0.5 [0.12]	0.6 [0.15]	0.7 [0.17]
2.0 [7.03]	High	Low	40,000 [11.72]	9 x 7 Blower 1/4 HP [186] 2 Speed (PSC Motor)	Low	CFM [l/s]	675 [319]	634 [299]	602 [284]	560 [264]	505 [238]	435 [205]
		Watts	695			870	905	940	980	1020		
	High	High	60,000 [17.58] 80,000 [23.45]			CFM [l/s]	898 [424]	822 [388]	777 [367]	721 [340]	651 [307]	562 [265]
2.5 [8.79]	Low	Low	All Inputs 40,000 [11.72] 60,000 [17.58] 80,000 [23.45] 100,000 [29.31]	10 x 9 Blower 1/2 HP [372] 3 Speed (PSC Motor)	Low	CFM [l/s]	1076 [508]	1032 [490]	996 [470]	950 [448]	896 [423]	832 [393]
		Watts				730	820	865	905	940	975	
	Med.	Low				CFM [l/s]	1222 [577]	1179 [556]	1162 [548]	1137 [537]	1097 [518]	1033 [488]
3.0 [10.55]	Med.	Low	All Inputs 40,000 [11.72] 60,000 [17.58] 80,000 [23.45] 100,000 [29.31]	10 x 9 Blower 1/2 HP [372] 3 Speed (PSC Motor)	Med.	CFM [l/s]	1461 [670]	1415 [668]	1370 [647]	1322 [624]	1266 [597]	1197 [565]
		Watts				423	407	397	386	370	351	
	High	Low				CFM [l/s]	1514 [715]	1415 [668]	1370 [647]	1322 [624]	1266 [597]	1197 [565]
3.5 [12.31]	High	Low	All Inputs 40,000 [11.72] 60,000 [17.58] 80,000 [23.45] 100,000 [29.31]	10 x 9 Blower 1/2 HP [372] 3 Speed (PSC Motor)	High	CFM [l/s]	1204 [568]	1191 [562]	1171 [553]	1143 [539]	1107 [522]	1065 [503]
		Watts				538	493	473	454	434	412	
	Low	High				CFM [l/s]	1674 [790]	1620 [765]	1566 [739]	1511 [713]	1451 [685]	1384 [653]
4.0 [14.07]	High	Low	All Inputs 40,000 [11.72] 60,000 [17.58] 80,000 [23.45] 100,000 [29.31]	10 x 9 Blower 3/4 HP [559] 3 Speed (PSC Motor)	Med.	CFM [l/s]	1843 [870]	1763 [832]	1693 [799]	1627 [768]	1560 [736]	1485 [701]
		Watts				625	596	567	539	512	484	455
	Low	High				CFM [l/s]	1085	1094	1102	1110	1118	1126
5.0 [17.59]	1st Stage Cool (Tap 2)	Low	100,000 [29.31]	12 x 9 Blower 1 HP [746] 4 Speed (X13 Motor)	Heat Dedicated (Tap 1)	CFM [l/s]	1418 [669]	1386 [654]	1307 [617]	1270 [599]	1221 [576]	1180 [557]
		Watts				774	794	829	860	892	922	955
	Med. (Tap 1)	High				CFM [l/s]	1310 [618]	1288 [608]	1238 [584]	1204 [568]	1149 [542]	1104 [521]
5.0 [17.59]	2nd Stage High Cool (Tap 4)	Low	100,000 [29.31]	12 x 9 Blower 1 HP [746] 4 Speed (X13 Motor)	2nd Stage Low Cool (Tap 3)	CFM [l/s]	1858 [877]	1821 [859]	1752 [827]	1714 [809]	1678 [792]	1640 [774]
		Watts				218	229	237	250	258	270	280
	High	High				CFM [l/s]	944	968	994	1019	1041	1072
5.0 [17.59]	2nd Stage High Cool (Tap 4)	Low	100,000 [29.31]	12 x 9 Blower 1 HP [746] 4 Speed (X13 Motor)	2nd Stage High Cool (Tap 4)	CFM [l/s]	2017 [952]	1985 [937]	1909 [901]	1879 [887]	1843 [870]	1792 [846]
		Watts				541	555	564	578	586	598	611
	High	High				CFM [l/s]	1018	1033	1070	1076	1112	1124
		Watts	690	701	711	723	735	741	742	742	Watts	690

NOTES: 5 ton 2nd stage cooling speed must be changed to low cool to achieve ARI performance.

[ ] Designates Metric Conversions

## INDOOR AIRFLOW PERFORMANCE—208 VOLTS (continued)

DOWN DISCHARGE PRESSURE DROP (ADD TO EXTERNAL STATIC PRESSURE)										
CFM [L/s]	600 [283]	800 [378]	1000 [472]	1200 [556]	1440 [661]	1600 [755]	1800 [850]	2000 [944]		
Pressure Drop—Includes W.C. [kPa]	.00	.02 [.005]	.05 [.012]	.07 [.017]	.1 [.025]	.12 [.030]	.15 [.037]	.17 [.042]		

[ ] Designates Metric Conversions



## INDOOR AIRFLOW PERFORMANCE—230 VOLTS

Nominal Cooling Capacity Tons [kW]	Motor Speed from Factory		Heating Input BTU/HR [kW]	Blower Size/ Motor HP [W] & # of Speeds	Motor Speed	External Static Pressure—Inches W.C. [kPa] Side Discharge—Wet Coil							
	Cool	Heat				0.1 [0.02]	0.2 [0.05]	0.3 [0.07]	0.4 [0.10]	0.5 [0.12]	0.6 [0.15]	0.7 [0.17]	
2.0 [7.03]	High	Low	40,000 [11.72]	9 x 7 Blower 1/4 HP [186] 2 Speed (PSC Motor)	Low	CFM [l/s]	771 [364]	751 [354]	725 [342]	691 [326]	654 [304]	584 [276]	546 [258]
						RPM	825	870	910	950	985	1010	1030
	High	High	60,000 [17.58] 80,000 [23.45]	CFM [l/s]	946 [446]	922 [435]	882 [416]	830 [392]	769 [363]	701 [331]	630 [298]	630 [298]	
2.5 [8.79]	Low	Low	All Inputs	10 x 9 Blower 1/2 HP [372] 3 Speed (PSC Motor)	Low	CFM [l/s]	1206 [569]	1182 [558]	1157 [546]	1128 [532]	1091 [515]	1044 [493]	983 [464]
						RPM	760	815	870	910	950	975	1000
	Med.	Low	40,000 [11.72] 60,000 [17.58] 80,000 [23.45] 100,000 [29.31]	CFM [l/s]	1411 [666]	1368 [646]	1327 [626]	1285 [606]	1238 [584]	1183 [558]	1116 [527]		
3.0 [10.55]	Med.	Low	All Inputs	10 x 9 Blower 3/4 HP [559] 3 Speed (PSC Motor)	Med.	RPM	865	900	935	970	1000	1020	1035
						Watts	498	481	464	447	430	411	391
	High	Low	100,000 [29.31]	CFM [l/s]	1641 [774]	1577 [744]	1515 [715]	1455 [687]	1393 [657]	1329 [627]	1262 [596]		
3.5 [12.31]	High	Low	All Inputs	10 x 9 Blower 3/4 HP [559] 3 Speed (PSC Motor)	High	RPM	980	1000	1020	1035	1050	1065	1080
						Watts	589	565	543	523	503	481	456
	High	Low	100,000 [29.31]	CFM [l/s]	1412 [668]	1395 [658]	1371 [647]	1339 [632]	1296 [612]	1242 [586]	1176 [555]		
4.0 [14.07]	High	Low	All Inputs	10 x 9 Blower 3/4 HP [559] 3 Speed (PSC Motor)	Low	RPM	859	905	951	981	1011	1034	1057
						Watts	557	530	506	483	461	437	409
	High	Low	60,000 [17.58] 80,000 [23.45] 100,000 [29.31]	CFM [l/s]	1793 [846]	1731 [817]	1665 [786]	1594 [752]	1519 [717]	1440 [680]	1356 [640]		
5.0 [17.59]	1st Stage Cool (Tap 2)	Med. (Tap 1)	100,000 [29.31]	12 x 9 Blower 1 HP [746] 4 Speed (X13 Motor)	High	RPM	1053	1067	1080	1091	1101	1110	1119
						Watts	667	637	606	574	543	512	483
	2nd Stage High Cool (Tap 4)	Low	100,000 [29.31]	CFM [l/s]	1869 [892]	1826 [862]	1753 [827]	1672 [789]	1586 [749]	1499 [707]	1413 [667]		
5.0 [17.59]	1st Stage Cool (Tap 2)	Med. (Tap 1)	100,000 [29.31]	12 x 9 Blower 1 HP [746] 4 Speed (X13 Motor)	High	RPM	1110	1117	1124	1129	1133	1139	1144
						Watts	736	715	683	646	608	574	551
	2nd Stage High Cool (Tap 4)	Low	100,000 [29.31]	CFM [l/s]	1423 [672]	1390 [656]	1357 [640]	1311 [619]	1277 [603]	1233 [582]	1192 [563]		
5.0 [17.59]	1st Stage Cool (Tap 2)	Med. (Tap 1)	100,000 [29.31]	12 x 9 Blower 1 HP [746] 4 Speed (X13 Motor)	High	RPM	776	796	830	861	895	927	958
						Watts	272	278	292	300	315	326	337
	2nd Stage High Cool (Tap 4)	Low	100,000 [29.31]	CFM [l/s]	1319 [622]	1289 [608]	1242 [586]	1201 [567]	1148 [542]	1111 [524]	1047 [494]		
5.0 [17.59]	1st Stage Cool (Tap 2)	Med. (Tap 1)	100,000 [29.31]	12 x 9 Blower 1 HP [746] 4 Speed (X13 Motor)	High	RPM	728	760	790	832	859	894	939
						Watts	222	234	241	256	263	276	287
	2nd Stage High Cool (Tap 4)	Low	100,000 [29.31]	CFM [l/s]	1872 [883]	1847 [872]	1808 [853]	1772 [836]	1743 [823]	1703 [804]	1670 [788]		
5.0 [17.59]	1st Stage Cool (Tap 2)	Med. (Tap 1)	100,000 [29.31]	12 x 9 Blower 1 HP [746] 4 Speed (X13 Motor)	High	RPM	956	973	1010	1023	1057	1085	1110
						Watts	562	572	584	598	613	622	636
	2nd Stage High Cool (Tap 4)	Low	100,000 [29.31]	CFM [l/s]	2046 [966]	2010 [949]	1980 [934]	1942 [917]	1904 [899]	1867 [881]	1822 [860]		
5.0 [17.59]	1st Stage Cool (Tap 2)	Med. (Tap 1)	100,000 [29.31]	12 x 9 Blower 1 HP [746] 4 Speed (X13 Motor)	High	RPM	1035	1046	1079	1086	1114	1141	1171
						Watts	721	731	743	754	770	777	770

NOTES: 5 ton 2nd stage cooling speed must be changed to low cool to achieve ARI performance.

[ ] Designates Metric Conversions

# AIRFLOW PERFORMANCE—TZGE-4 SERIES

## INDOOR AIRFLOW PERFORMANCE—208 VOLTS

Nominal Cooling Capacity Tons [kW]	Motor Speed from Factory		Heating Input BTU/HR [kW]	Blower Size/ Motor HP [W] & # of Speeds	Motor Speed	External Static Pressure—Inches W.C. [kPa] Side Discharge—Dry Coil								
	Cool	Heat				0.1 [ .02]	0.2 [ .05]	0.3 [ .07]	0.4 [ .10]	0.5 [ .12]	0.6 [ .15]	0.7 [ .17]	0.8 [ .20]	
2.0 [7.03]	High Cool (Tap 3)	Heat (Tap 1)	All Inputs 40,000 [11.72] 60,000 [17.58] 80,000 [23.45]	9 x 7 Blower 1/3 HP [249 W] 3 Speed (X13 Motor)	Heat Dedicated (Tap 1)	CFM [l/s]	821 [387]	799 [377]	775 [366]	742 [350]	706 [333]	681 [321]	641 [303]	611 [288]
						RPM	878	903	953	996	1032	1075	1119	1176
						Watts	131	134	142	145	147	154	156	161
2.5 [8.79]	High Cool (Tap 3)	Heat (Tap 1)	All Inputs 40,000 [11.72] 60,000 [17.58] 80,000 [23.45] 100,000 [29.31]	10 x 9 Blower 1/2 HP [372 W] 3 Speed (X13 Motor)	Low Cool (Tap 2)	CFM [l/s]	843 [398]	820 [387]	786 [371]	760 [359]	726 [343]	699 [330]	662 [312]	608 [287]
						RPM	896	924	961	1015	1045	1092	1125	1172
						Watts	141	144	147	155	157	163	165	164
3.0 [10.55]	High Cool (Tap 3)	Heat (Tap 1)	All Inputs 40,000 [11.72] 60,000 [17.58] 80,000 [23.45] 100,000 [29.31]	10 x 9 Blower 1/2 HP [372 W] 3 Speed (X13 Motor)	High Cool (Tap 3)	CFM [l/s]	896 [423]	884 [417]	847 [400]	825 [389]	789 [372]	752 [355]	720 [340]	642 [303]
						RPM	935	966	1008	1047	1084	1118	1154	1176
						Watts	165	171	175	182	184	186	189	174
3.5 [12.31]	High Cool (Tap 3)	Heat (Tap 1)	All Inputs 40,000 [11.72] 60,000 [17.58] 80,000 [23.45] 100,000 [29.31]	10 x 9 Blower 1/2 HP [372 W] 3 Speed (X13 Motor)	Heat Dedicated (Tap 1)	CFM [l/s]	1153 [544]	1126 [531]	1087 [513]	1042 [492]	1002 [473]	966 [456]	903 [426]	856 [404]
						RPM	866	887	930	966	1010	1038	1082	1121
						Watts	207	210	220	226	234	241	246	251
3.5 [12.31]	High Cool (Tap 3)	Heat (Tap 1)	All Inputs 40,000 [11.72] 60,000 [17.58] 80,000 [23.45] 100,000 [29.31]	10 x 9 Blower 1/2 HP [372 W] 3 Speed (X13 Motor)	Low Cool (Tap 2)	CFM [l/s]	1030 [486]	1010 [477]	967 [456]	922 [435]	868 [410]	825 [389]	763 [360]	709 [335]
						RPM	794	829	868	912	956	1002	1040	1093
						Watts	155	164	169	178	183	192	195	203
3.5 [12.31]	High Cool (Tap 3)	Heat (Tap 1)	All Inputs 40,000 [11.72] 60,000 [17.58] 80,000 [23.45] 100,000 [29.31]	10 x 9 Blower 1/2 HP [372 W] 3 Speed (X13 Motor)	High Cool (Tap 3)	CFM [l/s]	1242 [586]	1213 [572]	1173 [554]	1132 [534]	1086 [513]	1044 [493]	1003 [473]	952 [449]
						RPM	912	934	972	1012	1055	1081	1109	1146
						Watts	249	252	262	271	275	282	283	288
3.5 [12.31]	High Cool (Tap 3)	Heat (Tap 1)	All Inputs 40,000 [11.72] 60,000 [17.58] 80,000 [23.45] 100,000 [29.31]	10 x 9 Blower 1/2 HP [372 W] 3 Speed (X13 Motor)	Heat Dedicated (Tap 1)	CFM [l/s]	1153 [544]	1126 [531]	1087 [513]	1042 [492]	1002 [473]	966 [456]	903 [426]	856 [404]
						RPM	866	887	930	966	1010	1038	1082	1121
						Watts	207	210	220	226	234	241	246	251
3.5 [12.31]	High Cool (Tap 3)	Heat (Tap 1)	All Inputs 40,000 [11.72] 60,000 [17.58] 80,000 [23.45] 100,000 [29.31]	10 x 9 Blower 1/2 HP [372 W] 3 Speed (X13 Motor)	Low Cool (Tap 2)	CFM [l/s]	1242 [586]	1213 [572]	1173 [554]	1132 [534]	1086 [513]	1044 [493]	1003 [473]	952 [449]
						RPM	912	934	972	1012	1055	1081	1109	1146
						Watts	249	252	262	271	275	282	283	288
3.5 [12.31]	High Cool (Tap 3)	Heat (Tap 1)	All Inputs 40,000 [11.72] 60,000 [17.58] 80,000 [23.45] 100,000 [29.31]	10 x 9 Blower 1/2 HP [372 W] 3 Speed (X13 Motor)	High Cool (Tap 3)	CFM [l/s]	1338 [631]	1309 [618]	1278 [603]	1234 [582]	1182 [558]	1135 [536]	1087 [513]	1007 [475]
						RPM	963	983	1016	1049	1096	1121	1142	1159
						Watts	304	307	316	321	328	332	330	315
3.5 [12.31]	High Cool (Tap 3)	Heat (Tap 1)	All Inputs 40,000 [11.72] 60,000 [17.58] 80,000 [23.45] 100,000 [29.31]	10 x 9 Blower 1/2 HP [372 W] 3 Speed (X13 Motor)	Heat Dedicated (Tap 1)	CFM [l/s]	1228 [580]	1187 [560]	1140 [538]	1105 [522]	1062 [501]	1008 [476]	959 [453]	911 [430]
						RPM	761	808	841	884	920	960	999	1038
						Watts	150	170	180	183	185	190	195	215
3.5 [12.31]	High Cool (Tap 3)	Heat (Tap 1)	All Inputs 40,000 [11.72] 60,000 [17.58] 80,000 [23.45] 100,000 [29.31]	10 x 9 Blower 1/2 HP [372 W] 3 Speed (X13 Motor)	Low Cool (Tap 2)	CFM [l/s]	1454 [686]	1433 [676]	1392 [657]	1354 [639]	1322 [624]	1283 [606]	1238 [584]	1192 [563]
						RPM	923	946	976	1015	1044	1085	1126	1146
						Watts	301	309	316	327	337	348	356	363
3.5 [12.31]	High Cool (Tap 3)	Heat (Tap 1)	All Inputs 40,000 [11.72] 60,000 [17.58] 80,000 [23.45] 100,000 [29.31]	10 x 9 Blower 1/2 HP [372 W] 3 Speed (X13 Motor)	High Cool (Tap 3)	CFM [l/s]	1544 [729]	1531 [723]	1473 [695]	1440 [680]	1398 [660]	1361 [642]	1317 [622]	1263 [596]
						RPM	958	973	1025	1046	1078	1109	1147	1163
						Watts	343	350	364	371	382	391	401	396

NOTES: (1) Do not operate 2 ton models below 700 CFM. (2) Do not operate 2 1/2 or 3 ton models below 875 CFM. (3) Cooling speed must be changed to low cool to achieve ARI performance (all models).

[ ] Designates Metric Conversions

## INDOOR AIRFLOW PERFORMANCE—208 VOLTS (continued)

Nominal Cooling Capacity Tons [kW]	Motor Speed from Factory		Heating Input BTU/HR [kW]	Blower Size/ Motor HP [W] & # of Speeds	Motor Speed	External Static Pressure—Inches W.C. [kPa] Side Discharge—Dry Coil								
	Cool	Heat				0.1 [.02]	0.2 [.05]	0.3 [.07]	0.4 [.10]	0.5 [.12]	0.6 [.15]	0.7 [.17]	0.8 [.20]	
4.0 [14.07]	High Cool (Tap 3)	Heat (Tap 1)	All Inputs 60,000 [17.58] 80,000 [23.45] 100,000 [29.31]	10 x 9 Blower 3/4 HP [555 W] 3 Speed (X13 Motor)	Heat Dedicated (Tap 1)	CFM [l/s]	1454 [686]	1433 [676]	1392 [657]	1354 [639]	1322 [624]	1283 [606]	1238 [584]	1192 [563]
					Low Cool (Tap 2)	RPM	923	946	976	1015	1044	1085	1126	1146
					Watts	301	309	316	327	337	348	356	363	
5.0 [17.59]	2nd Stage High Cool (Tap 4)	Med. (Tap 1)	100,000 [29.31]	12 x 9 1 HP [746 W] 4 Speed (X13 Motor)	High Cool (Tap 3)	CFM [l/s]	1642 [775]	1621 [765]	1584 [748]	1542 [728]	1496 [706]	1451 [685]	1396 [659]	1299 [613]
					1st Stage Cool (Tap 2)	RPM	1006	1022	1064	1090	1114	1151	1160	1172
					Watts	405	412	422	435	442	449	440	414	
5.0 [17.59]	1st Stage Cool (Tap 2)	Med. (Tap 1)	100,000 [29.31]	12 x 9 1 HP [746 W] 4 Speed (X13 Motor)	High Cool (Tap 3)	CFM [l/s]	1896 [895]	1863 [879]	1776 [838]	1694 [799]	1603 [757]	1528 [721]	1424 [672]	1316 [621]
					Heat Dedicated (Tap 1)	RPM	1146	1147	1159	1171	1173	1180	1188	1195
					Watts	624	614	583	554	522	497	467	432	
5.0 [17.59]	2nd Stage High Cool (Tap 4)	Med. (Tap 1)	100,000 [29.31]	12 x 9 1 HP [746 W] 4 Speed (X13 Motor)	Heat Dedicated (Tap 1)	CFM [l/s]	1418 [669]	1386 [654]	1352 [638]	1307 [617]	1270 [599]	1221 [576]	1180 [557]	1117 [527]
					1st Stage Cool (Tap 2)	RPM	774	794	829	860	892	922	955	1015
					Watts	267	273	287	295	308	316	328	343	
5.0 [17.59]	2nd Stage High Cool (Tap 4)	Med. (Tap 1)	100,000 [29.31]	12 x 9 1 HP [746 W] 4 Speed (X13 Motor)	2nd Stage Low Cool (Tap 3)	CFM [l/s]	1310 [618]	1288 [608]	1238 [584]	1204 [568]	1149 [542]	1104 [521]	1035 [488]	971 [458]
					1st Stage Cool (Tap 2)	RPM	731	757	789	826	857	894	937	993
					Watts	218	229	237	250	258	270	280	294	
5.0 [17.59]	2nd Stage High Cool (Tap 4)	Med. (Tap 1)	100,000 [29.31]	12 x 9 1 HP [746 W] 4 Speed (X13 Motor)	2nd Stage Low Cool (Tap 3)	CFM [l/s]	1858 [877]	1821 [859]	1782 [841]	1752 [827]	1714 [809]	1678 [792]	1640 [774]	1607 [758]
					Heat Dedicated (Tap 1)	RPM	944	968	994	1019	1041	1072	1089	1111
					Watts	541	555	564	578	586	598	611	617	
5.0 [17.59]	2nd Stage High Cool (Tap 4)	Med. (Tap 1)	100,000 [29.31]	12 x 9 1 HP [746 W] 4 Speed (X13 Motor)	2nd Stage High Cool (Tap 4)	CFM [l/s]	2017 [952]	1985 [937]	1949 [920]	1909 [901]	1879 [887]	1843 [870]	1792 [846]	1737 [820]
					Heat Dedicated (Tap 1)	RPM	1018	1033	1070	1076	1112	1124	1147	1152
					Watts	690	701	711	723	735	741	742	728	

NOTES: (1) Do not operate 2 ton models below 700 CFM. (2) Do not operate 2 1/2 or 3 ton models below 875 CFM. (3) Cooling speed must be changed to low cool to achieve ARI performance (all models).

[ ] Designates Metric Conversions

DOWN DISCHARGE PRESSURE DROP (ADD TO EXTERNAL STATIC PRESSURE)								
CFM [l/s]	600 [283]	800 [378]	1000 [472]	1200 [566]	1400 [661]	1600 [755]	1800 [849]	2000 [944]
Pressure Drop—Includes W.C. [kPa]	0	.02 [.005]	.05 [.012]	.07 [.017]	.1 [.025]	.12 [.030]	.15 [.037]	.17 [.042]

# AIRFLOW PERFORMANCE—TZGE-4 SERIES

## INDOOR AIRFLOW PERFORMANCE—230 VOLTS

Nominal Cooling Capacity Tons [kW]	Motor Speed from Factory		Heating Input BTU/HR [kW]	Blower Size/ Motor HP [W] & # of Speeds	Motor Speed	External Static Pressure—Inches W.C. [kPa] Side Discharge—Dry Coil									
	Cool	Heat				0.1 [0.02]	0.2 [0.05]	0.3 [0.07]	0.4 [1.10]	0.5 [1.12]	0.6 [1.15]	0.7 [1.17]	0.8 [1.20]		
2.0 [7.03]	High Cool (Tap 3)	Heat (Tap 1)	All Inputs 40,000 [11.72] 60,000 [17.58] 80,000 [23.45]	9 x 7 Blower 1/3 HP [249 W] 3 Speed (X13 Motor)	Heat Dedicated (Tap 1)	CFM [l/s]	829 [391]	808 [381]	789 [372]	756 [357]	737 [348]	697 [329]	668 [315]	615 [290]	
						RPM	890	915	961	1000	1046	1089	1121	1173	
						Watts	137	139	148	151	160	163	166	167	
2.5 [8.79]	High Cool (Tap 3)	Heat (Tap 1)	All Inputs 40,000 [11.72] 60,000 [17.58] 80,000 [23.45] 100,000 [29.31]	10 x 9 Blower 1/2 HP [372 W] 3 Speed (X13 Motor)	Low Cool (Tap 2)	CFM [l/s]	853 [403]	832 [393]	804 [379]	779 [368]	745 [352]	724 [342]	688 [325]	630 [297]	
						RPM	901	928	984	1013	1054	1099	1137	1185	
						Watts	146	149	159	161	165	173	176	173	
3.0 [10.55]	High Cool (Tap 3)	Heat (Tap 1)	All Inputs 40,000 [11.72] 60,000 [17.58] 80,000 [23.45] 100,000 [29.31]	10 x 9 Blower 1/2 HP [372 W] 3 Speed (X13 Motor)	High Cool (Tap 3)	CFM [l/s]	912 [430]	896 [423]	863 [407]	839 [396]	815 [385]	787 [371]	736 [347]	656 [310]	
						RPM	940	977	1017	1062	1088	1139	1165	1181	
						Watts	171	179	183	192	194	203	199	182	
3.5 [12.31]	High Cool (Tap 3)	Heat (Tap 1)	All Inputs 40,000 [11.72] 60,000 [17.58] 80,000 [23.45] 100,000 [29.31]	10 x 9 Blower 1/2 HP [372 W] 3 Speed (X13 Motor)	Heat Dedicated (Tap 1)	CFM [l/s]	1169 [552]	1140 [538]	1111 [524]	1068 [504]	1030 [486]	995 [470]	949 [448]	895 [422]	
						RPM	868	893	932	978	1010	1048	1086	1129	
						Watts	213	217	228	239	244	254	258	268	
3.5 [12.31]	High Cool (Tap 3)	Heat (Tap 1)	All Inputs 40,000 [11.72] 60,000 [17.58] 80,000 [23.45] 100,000 [29.31]	10 x 9 Blower 1/2 HP [372 W] 3 Speed (X13 Motor)	Low Cool (Tap 2)	CFM [l/s]	1039 [490]	1021 [482]	971 [458]	932 [440]	887 [419]	839 [396]	797 [376]	735 [347]	
						RPM	798	833	878	922	955	1011	1061	1093	
						Watts	159	168	175	185	189	200	210	213	
3.5 [12.31]	High Cool (Tap 3)	Heat (Tap 1)	All Inputs 40,000 [11.72] 60,000 [17.58] 80,000 [23.45] 100,000 [29.31]	10 x 9 Blower 1/2 HP [372 W] 3 Speed (X13 Motor)	High Cool (Tap 3)	CFM [l/s]	1256 [593]	1231 [581]	1201 [567]	1161 [548]	1115 [526]	1076 [508]	1043 [492]	999 [471]	
						RPM	921	942	976	1018	1053	1093	1131	1149	
						Watts	259	263	272	284	290	299	309	307	
3.5 [12.31]	High Cool (Tap 3)	Heat (Tap 1)	All Inputs 40,000 [11.72] 60,000 [17.58] 80,000 [23.45] 100,000 [29.31]	10 x 9 Blower 1/2 HP [372 W] 3 Speed (X13 Motor)	Heat Dedicated (Tap 1)	CFM [l/s]	1169 [552]	1140 [538]	1111 [524]	1068 [504]	1030 [486]	995 [470]	949 [448]	895 [422]	
						RPM	868	893	932	978	1010	1048	1086	1129	
						Watts	213	217	228	239	244	254	258	268	
3.5 [12.31]	High Cool (Tap 3)	Heat (Tap 1)	All Inputs 40,000 [11.72] 60,000 [17.58] 80,000 [23.45] 100,000 [29.31]	10 x 9 Blower 1/2 HP [372 W] 3 Speed (X13 Motor)	Low Cool (Tap 2)	CFM [l/s]	1256 [593]	1231 [581]	1201 [567]	1161 [548]	1115 [526]	1076 [508]	1043 [492]	999 [471]	
						RPM	921	942	976	1018	1053	1093	1131	1149	
						Watts	259	263	272	284	290	299	309	307	
3.5 [12.31]	High Cool (Tap 3)	Heat (Tap 1)	All Inputs 40,000 [11.72] 60,000 [17.58] 80,000 [23.45] 100,000 [29.31]	10 x 9 Blower 1/2 HP [372 W] 3 Speed (X13 Motor)	High Cool (Tap 3)	CFM [l/s]	1357 [640]	1330 [628]	1292 [610]	1262 [596]	1225 [578]	1178 [556]	1110 [524]	1033 [488]	
						RPM	974	1003	1036	1071	1103	1134	1153	1169	
						Watts	318	323	333	343	347	356	345	328	
3.5 [12.31]	High Cool (Tap 3)	Heat (Tap 1)	All Inputs 40,000 [11.72] 60,000 [17.58] 80,000 [23.45] 100,000 [29.31]	10 x 9 Blower 1/2 HP [372 W] 3 Speed (X13 Motor)	Heat Dedicated (Tap 1)	CFM [l/s]	1241 [586]	1203 [568]	1155 [545]	1119 [528]	1082 [511]	1032 [487]	994 [469]	950 [448]	
						RPM	771	815	848	886	932	965	1004	1044	
						Watts	155	162	170	182	193	200	210	220	
3.5 [12.31]	High Cool (Tap 3)	Heat (Tap 1)	All Inputs 40,000 [11.72] 60,000 [17.58] 80,000 [23.45] 100,000 [29.31]	10 x 9 Blower 1/2 HP [372 W] 3 Speed (X13 Motor)	Low Cool (Tap 2)	CFM [l/s]	1459 [689]	1438 [679]	1409 [665]	1371 [647]	1337 [631]	1296 [612]	1258 [594]	1223 [577]	
						RPM	931	958	993	1031	1058	1097	1133	1158	
						Watts	308	319	331	339	349	362	373	381	
3.5 [12.31]	High Cool (Tap 3)	Heat (Tap 1)	All Inputs 40,000 [11.72] 60,000 [17.58] 80,000 [23.45] 100,000 [29.31]	10 x 9 Blower 1/2 HP [372 W] 3 Speed (X13 Motor)	High Cool (Tap 3)	CFM [l/s]	1562 [737]	1538 [726]	1500 [708]	1456 [687]	1434 [677]	1383 [653]	1339 [632]	1270 [599]	
						RPM	960	991	1017	1055	1089	1121	1154	1169	
						Watts	353	364	375	388	398	408	418	405	

NOTES: (1) Do not operate 2 ton models below 700 CFM. (2) Do not operate 2 1/2 or 3 ton models below 875 CFM. (3) Cooling speed must be changed to low cool to achieve ARI performance (all models).

[ ] Designates Metric Conversions

## INDOOR AIRFLOW PERFORMANCE—230 VOLTS (continued)

Nominal Cooling Capacity Tons [kW]	Motor Speed from Factory		Heating Input BTU/HR [kW]	Blower Size/ Motor HP [W] & # of Speeds	Motor Speed	External Static Pressure—Inches W.C. [kPa] Side Discharge—Dry Coil													
	Cool	Heat				0.1 [0.02]	0.2 [0.05]	0.3 [0.07]	0.4 [0.10]	0.5 [0.12]	0.6 [0.15]	0.7 [0.17]	0.8 [0.20]						
4.0 [14.07]	High Cool (Tap 3)	Heat (Tap 1)	All Inputs 60,000 [17.58] 80,000 [23.45] 100,000 [29.31]	10 x 9 Blower 3/4 HP [555 W] 3 Speed (X13 Motor)	Heat Dedicated (Tap 1)	CFM [l/s]	1459 [689]	1438 [679]	1409 [665]	1371 [647]	1337 [631]	1296 [612]	1258 [594]	1223 [577]					
						RPM	931	958	993	1031	1058	1097	1133	1158					
						Watts	308	319	331	339	349	362	373	381					
	Low Cool (Tap 2)	Heat (Tap 1)	All Inputs 60,000 [17.58] 80,000 [23.45] 100,000 [29.31]	10 x 9 Blower 3/4 HP [555 W] 3 Speed (X13 Motor)	Low Cool (Tap 2)	CFM [l/s]	1662 [784]	1648 [778]	1607 [758]	1579 [745]	1538 [726]	1477 [697]	1392 [657]	1305 [616]					
						RPM	1016	1037	1072	1098	1129	1156	1169	1179					
						Watts	421	429	443	453	465	465	446	420					
High Cool (Tap 3)	Heat (Tap 1)	All Inputs 60,000 [17.58] 80,000 [23.45] 100,000 [29.31]	10 x 9 Blower 3/4 HP [555 W] 3 Speed (X13 Motor)	High Cool (Tap 3)	CFM [l/s]	1910 [901]	1873 [884]	1798 [849]	1715 [809]	1621 [765]	1536 [725]	1422 [671]	1323 [624]						
					RPM	1149	1160	1163	1169	1175	1187	1184	1205						
					Watts	638	625	601	571	536	506	469	440						
5.0 [17.59]	1st Stage Cool (Tap 2)	Med. (Tap 1)	100,000 [29.31]	12 x 9 Blower 1 HP [746 W] 4 Speed (X13 Motor)	Heat Dedicated (Tap 1)	CFM [l/s]	1423 [672]	1390 [656]	1357 [640]	1311 [619]	1277 [603]	1233 [582]	1192 [563]	1137 [537]					
						RPM	776	796	830	861	895	927	958	999					
						Watts	272	278	292	300	315	326	337	352					
						2nd Stage High Cool (Tap 4)	Med. (Tap 1)	100,000 [29.31]	12 x 9 Blower 1 HP [746 W] 4 Speed (X13 Motor)	1st Stage Cool (Tap 2)	CFM [l/s]	1319 [622]	1289 [608]	1242 [586]	1201 [567]	1148 [542]	1111 [524]	1047 [494]	985 [465]
											RPM	728	760	790	832	859	894	939	992
											Watts	222	234	241	256	263	276	287	304
	2nd Stage High Cool (Tap 4)	Med. (Tap 1)	100,000 [29.31]	12 x 9 Blower 1 HP [746 W] 4 Speed (X13 Motor)	2nd Stage Low Cool (Tap 3)	CFM [l/s]	1872 [883]	1847 [872]	1808 [853]	1772 [836]	1743 [823]	1703 [804]	1670 [788]	1639 [774]					
						RPM	956	973	1010	1023	1057	1085	1110	1146					
						Watts	562	572	584	598	613	622	636	646					
						2nd Stage High Cool (Tap 4)	Med. (Tap 1)	100,000 [29.31]	12 x 9 Blower 1 HP [746 W] 4 Speed (X13 Motor)	2nd Stage High Cool (Tap 4)	CFM [l/s]	2046 [966]	2010 [949]	1980 [934]	1942 [917]	1904 [899]	1867 [881]	1822 [860]	1758 [830]
											RPM	1035	1046	1079	1086	1114	1141	1171	1163
											Watts	721	731	743	754	770	777	770	751

NOTES: (1) Do not operate 2 ton models below 700 CFM. (2) Do not operate 2 1/2 or 3 ton models below 875 CFM. (3) Cooling speed must be changed to low cool to achieve ARI performance (all models).

[ ] Designates Metric Conversions

DOWN DISCHARGE PRESSURE DROP (ADD TO EXTERNAL STATIC PRESSURE)				
CFM [l/s]	600 [283]	800 [378]	1000 [472]	2000 [944]
Pressure Drop—Includes W.C. [kPa]	0	.02 [.005]	.05 [.012]	.17 [.042]

# ELECTRICAL DATA—TZGE-3 SERIES

ELECTRICAL DATA – TZGE-3 SERIES									
		324JL040	324JL060	324JL080	330JL060	330JL080	330JL100	336CL080	336CL100
Unit Information	Unit Operating Voltage Range	187-253	187-253	187-253	187-253	187-253	187-253	187-253	187-253
	Minimum Circuit Ampacity	19/19	19/19	19/19	22/22	22/22	22/22	17/17	17/17
	Minimum Overcurrent Protection Device Size	20/20	20/20	20/20	25/25	25/25	25/25	20/20	20/20
	Maximum Overcurrent Protection Device Size	30/30	30/30	30/30	35/35	35/35	35/35	25/25	25/25
Compressor Motor	No.	1	1	1	1	1	1	1	1
	Volts	208/230	208/230	208/230	208/230	208/230	208/230	208/230	208/230
	Phase	1	1	1	1	1	1	3	3
	HP	2 1/6	2 1/6	2 1/6	2 2/3	2 2/3	2 2/3	3 1/3	3 1/3
	RPM	3450	3450	3450	3450	3450	3450	3450	3450
	Amps (RLA)	12.8/12.8	12.8/12.8	12.8/12.8	14.1/14.1	14.1/14.1	14.1/14.1	10.4/10.4	10.4/10.4
	Amps (LRA)	58.3/58.3	58.3/58.3	58.3/58.3	73/73	73/73	73/73	88/88	88/88
Condenser Motor	No.	1	1	1	1	1	1	1	1
	Volts	208/230	208/230	208/230	208/230	208/230	208/230	208/230	208/230
	Phase	1	1	1	1	1	1	1	1
	HP	1/3	1/3	1/3	1/3	1/3	1/3	1/3	1/3
	Amps (FLA)	1.3	1.3	1.3	1.3	1.3	1.3	1.3	1.3
	Amps (LRA)	2.3	2.3	2.3	2.3	2.3	2.3	2.3	2.3
Evaporator Fan	No.	1	1	1	1	1	1	1	1
	Volts	208/230	208/230	208/230	208/230	208/230	208/230	208/230	208/230
	Phase	1	1	1	1	1	1	1	1
	HP	1/4	1/4	1/4	1/2	1/2	1/2	1/2	1/2
	Amps (FLA)	1.3	1.3	1.3	2.4	2.4	2.4	2.4	2.4
	Amps (LRA)	2.3	2.3	2.3	5.1	5.1	5.1	5.1	5.1

1. Horsepower Per Compressor.

2. Amp Draw Per Motor. Multiply Value By Number of Motors to Determine Total Amps.

# ELECTRICAL DATA—TZGE-3 SERIES

ELECTRICAL DATA – TZGE-3 SERIES									
		336JL080	336JL100	342CL100	342JL100	348CL100	348JL100	360CL100	360JL100
Unit Information	Unit Operating Voltage Range	187-253	187-253	187-253	187-253	187-253	187-253	197-253	197-253
	Minimum Circuit Ampacity	25/25	25/25	22/22	27/27	24/24	34/34	32/32	42/42
	Minimum Overcurrent Protection Device Size	25/25	25/25	25/25	30/30	25/25	35/35	35/35	45/45
	Maximum Overcurrent Protection Device Size	40/40	40/40	30/30	40/40	35/35	50/50	45/45	60/60
Compressor Motor	No.	1	1	1	1	1	1	1	1
	Volts	208/230	208/230	208/230	208/230	208/230	208/230	208/230	208/230
	Phase	1	1	3	1	3	1	3	1
	HP	3 1/3	3 1/3	3 1/2	3 1/2	4	4	5	5
	RPM	3450	3450	3450	3450	3450	3450	3450	3450
	Amps (RLA)	16.7/16.7	16.7/16.7	13.5/13.5	17.9/17.9	13.7/13.7	21.8/21.8	17.6/17.6	25.6/25.6
	Amps (LRA)	79/79	79/79	88/88	112/112	83.1/83.1	117/117	123/123	118/118
Condenser Motor	No.	1	1	1	1	1	1	1	1
	Volts	208/230	208/230	208/230	208/230	208/230	208/230	208/230	208/230
	Phase	1	1	1	1	1	1	1	1
	HP	1/3	1/3	1/3	1/3	1/3	1/3	1/3	1/3
	Amps (FLA)	1.3	1.3	2	2	2	2	2	2
	Amps (LRA)	2.3	2.3	3.9	3.9	3.9	3.9	3.9	3.9
Evaporator Fan	No.	1	1	1	1	1	1	1	1
	Volts	208/230	208/230	208/230	208/230	208/230	208/230	208/230	208/230
	Phase	1	1	1	1	1	1	1	1
	HP	1/2	1/2	1/2	1/2	3/4	3/4	1	1
	Amps (FLA)	2.4	2.4	2.4	2.4	4.4	4.4	7.6	7.6
	Amps (LRA)	5.1	5.1	5.1	5.1	9.5	9.5	0	0

1. Horsepower Per Compressor.

2. Amp Draw Per Motor. Multiply Value By Number of Motors to Determine Total Amps.



# ELECTRICAL DATA—TZGE-4 SERIES

ELECTRICAL DATA – TZGE-4 SERIES									
		424JL040	424JL060	424JL080	430JL060	430JL080	430JL100	436CL080	430CL100
Unit Information	Unit Operating Voltage Range	187-253	187-253	187-253	187-253	187-253	187-253	187-253	187-253
	Minimum Circuit Ampacity	21/21	21/21	21/21	24/24	24/24	24/24	19/19	19/19
	Minimum Overcurrent Protection Device Size	25/25	25/25	25/25	25/25	25/25	25/25	20/20	20/20
	Maximum Overcurrent Protection Device Size	30/30	30/30	30/30	35/35	35/35	35/35	25/25	25/25
Compressor Motor	No.	1	1	1	1	1	1	1	1
	Volts	208/230	208/230	208/230	208/230	208/230	208/230	208/230	208/230
	Phase	1	1	1	1	1	1	3	3
	HP	2 1/6	2 1/6	2 1/6	2 2/3	2 2/3	2 2/3	3 1/3	3 1/3
	RPM	3450	3450	3450	3450	3450	3450	3450	3450
	Amps (RLA)	12.8/12.8	12.8/12.8	12.8/12.8	14.1/14.1	14.1/14.1	14.1/14.1	10.4/10.4	10.4/10.4
	Amps (LRA)	58.3/58.3	58.3/58.3	58.3/58.3	73/73	73/73	73/73	88/88	88/88
Condenser Motor	No.	1	1	1	1	1	1	1	1
	Volts	208/230	208/230	208/230	208/230	208/230	208/230	208/230	208/230
	Phase	1	1	1	1	1	1	1	1
	HP	1/3	1/3	1/3	1/3	1/3	1/3	1/3	1/3
	Amps (FLA)	1.3	1.3	1.3	1.3	1.3	1.3	1.3	1.3
	Amps (LRA)	2.3	2.3	2.3	2.3	2.3	2.3	2.3	2.3
Evaporator Fan	No.	1	1	1	1	1	1	1	1
	Volts	208/230	208/230	208/230	208/230	208/230	208/230	208/230	208/230
	Phase	1	1	1	1	1	1	1	1
	HP	1/3	1/3	1/3	1/2	1/2	1/2	1/2	1/2
	Amps (FLA)	2.8	2.8	2.8	4.1	4.1	4.1	4.1	4.1
	Amps (LRA)	0	0	0	0	0	0	0	0

1. Horsepower Per Compressor.

2. Amp Draw Per Motor. Multiply Value By Number of Motors to Determine Total Amps.

ELECTRICAL DATA – TZGE-4 SERIES									
		436JL080	436JL100	442CL100	442JL100	448CL100	448JL100	460CL100	460JL100
<b>Unit Information</b>	Unit Operating Voltage Range	187-253	187-253	187-253	187-253	187-253	187-253	197-253	197-253
	Minimum Circuit Ampacity	27/27	27/27	24/24	29/29	26/26	36/36	32/32	42/42
	Minimum Overcurrent Protection Device Size	30/30	30/30	25/25	30/30	30/30	40/40	35/35	45/45
	Maximum Overcurrent Protection Device Size	40/40	40/40	35/35	45/45	35/35	50/50	45/45	60/60
<b>Compressor Motor</b>	No.	1	1	1	1	1	1	1	1
	Volts	208/230	208/230	208/230	208/230	208/230	208/230	208/230	208/230
	Phase	1	1	3	1	3	1	3	1
	HP	3 1/3	3 1/3	3 1/2	3 1/2	4	4	5	5
	RPM	3450	3450	3450	3450	3450	3450	3450	3450
	Amps (RLA)	16.7/16.7	16.7/16.7	13.5/13.5	17.9/17.9	13.7/13.7	21.8/21.8	17.6/17.6	25.6/25.6
	Amps (LRA)	79/79	79/79	88/88	112/112	83.1/83.1	117/117	123/123	118/118
<b>Condenser Motor</b>	No.	1	1	1	1	1	1	1	1
	Volts	208/230	208/230	208/230	208/230	208/230	208/230	208/230	208/230
	Phase	1	1	1	1	1	1	1	1
	HP	1/3	1/3	1/3	1/3	1/3	1/3	1/3	1/3
	Amps (FLA)	1.3	1.3	2	2	2	2	2	2
	Amps (LRA)	2.3	2.3	3.9	3.9	3.9	3.9	3.9	3.9
<b>Evaporator Fan</b>	No.	1	1	1	1	1	1	1	1
	Volts	208/230	208/230	208/230	208/230	208/230	208/230	208/230	208/230
	Phase	1	1	1	1	1	1	1	1
	HP	1/2	1/2	1/2	1/2	3/4	3/4	1	1
	Amps (FLA)	4.1	4.1	4.1	4.1	6	6	7.6	7.6
	Amps (LRA)	0	0	0	0	0	0	0	0

1. Horsepower Per Compressor.  
 2. Amp Draw Per Motor. Multiply Value By Number of Motors to Determine Total Amps.

# UNIT DIMENSIONS—TZGE-3/TZGE-4 SERIES

## UNIT DIMENSIONS GAS HEAT/ELECTRIC COOLING PACKAGE

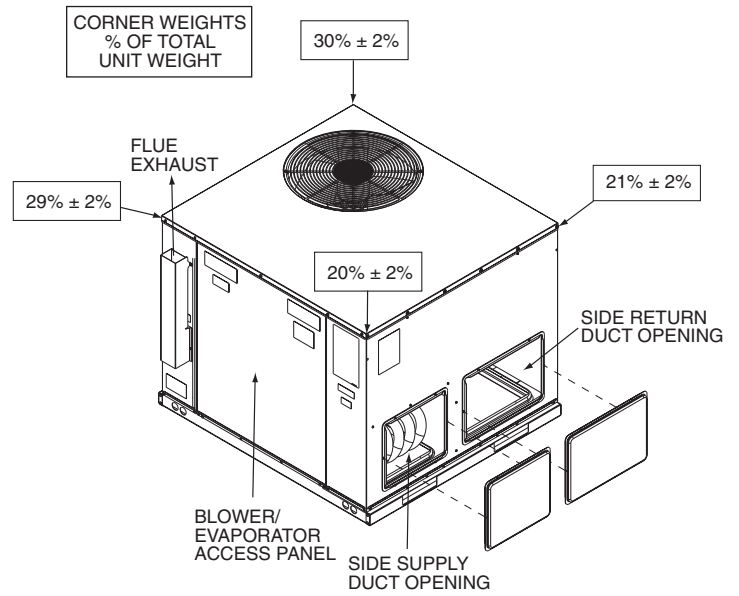
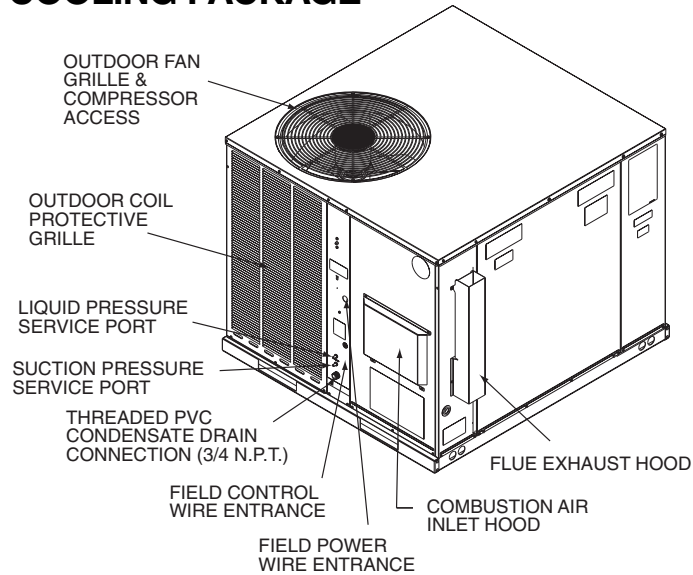

**TOP VIEW**

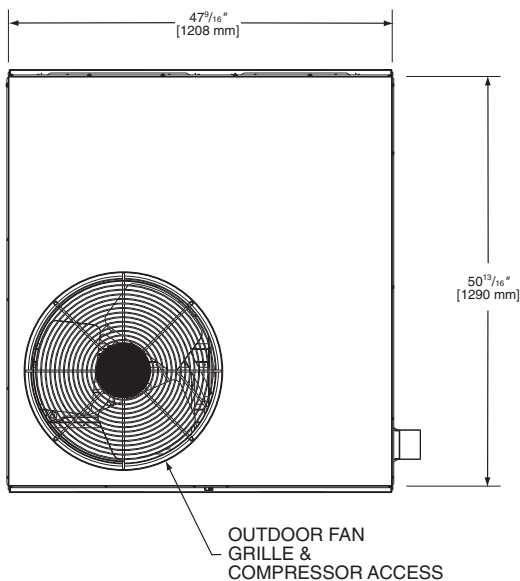

**BOTTOM VIEW**

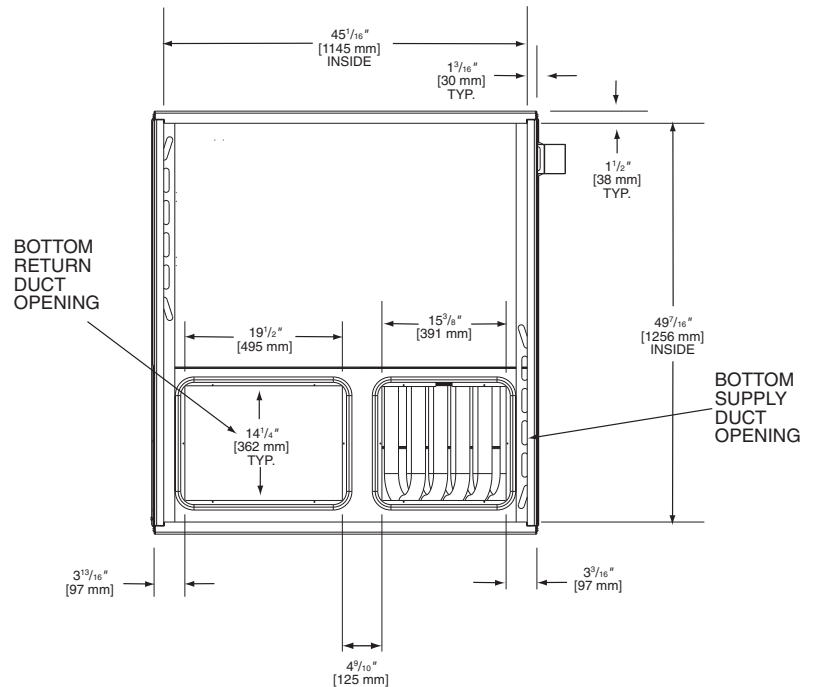

[ ] Designates Metric Conversions

# UNIT DIMENSIONS—TZGE-3/TZGE-4 SERIES

## SIDE VIEW

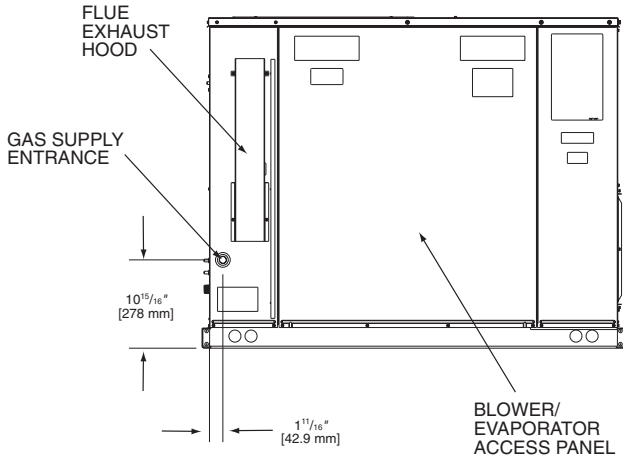

## SIDE VIEW

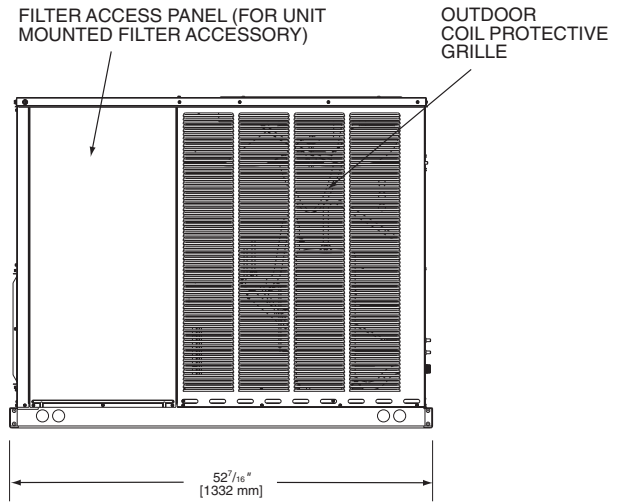

## FRONT VIEW

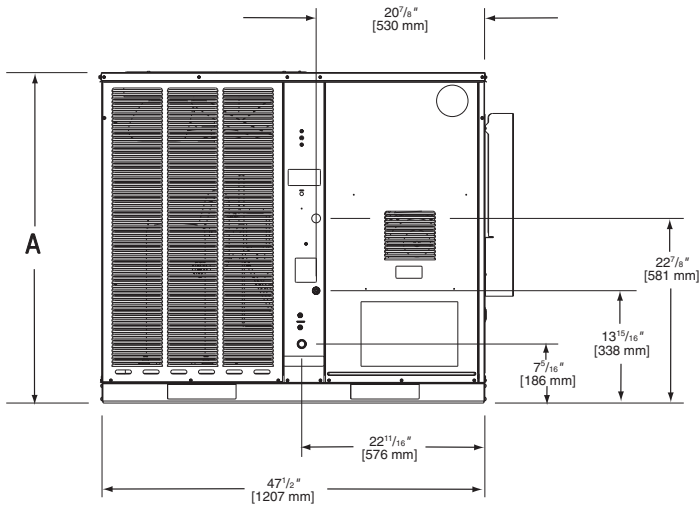

## BACK VIEW

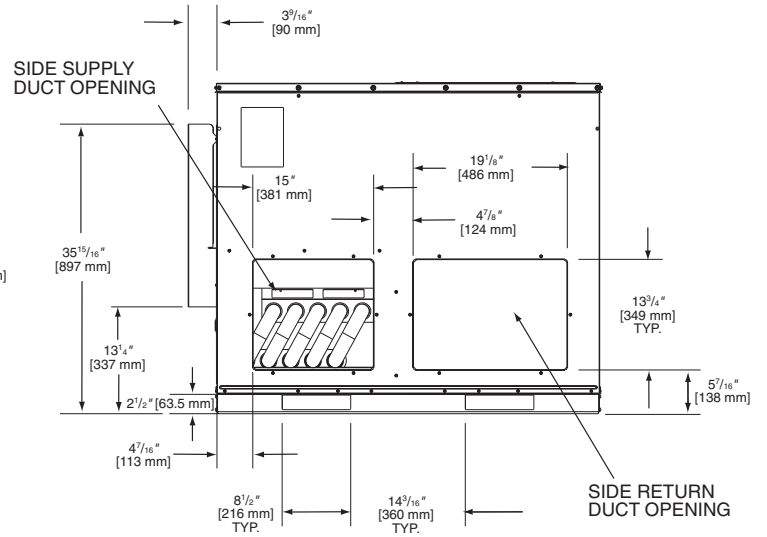

SHOWN WITH DUCT COVERS REMOVED.

Models: TZGE-3/TZGE-4	Model: RRRL	"A" Height
B024, B030, B036	B024	$35^{15}/16"$
B042, B048, B060	B036, B048, B060	41"

[ ] Designates Metric Conversions

# TYPICAL INSTALLATIONS

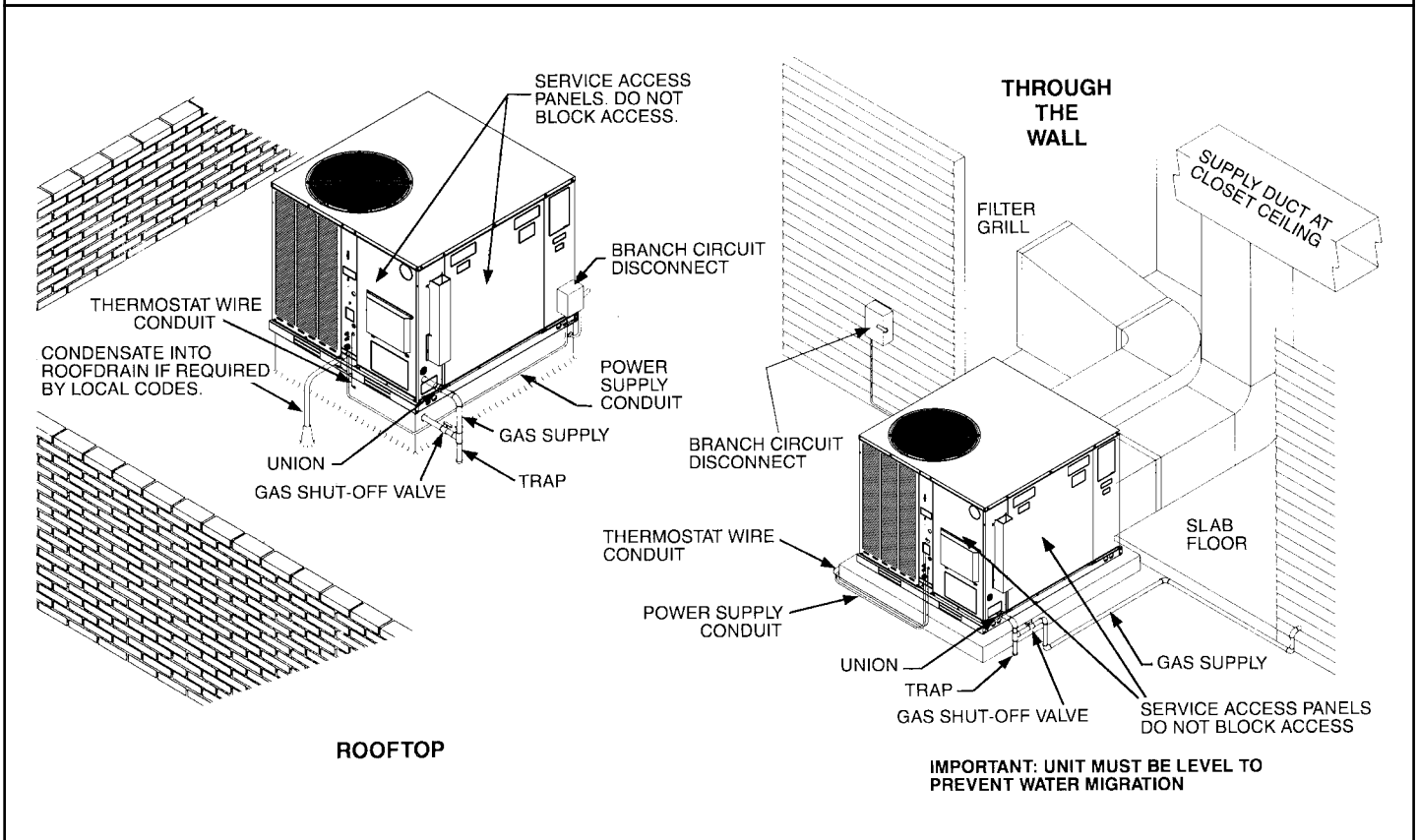
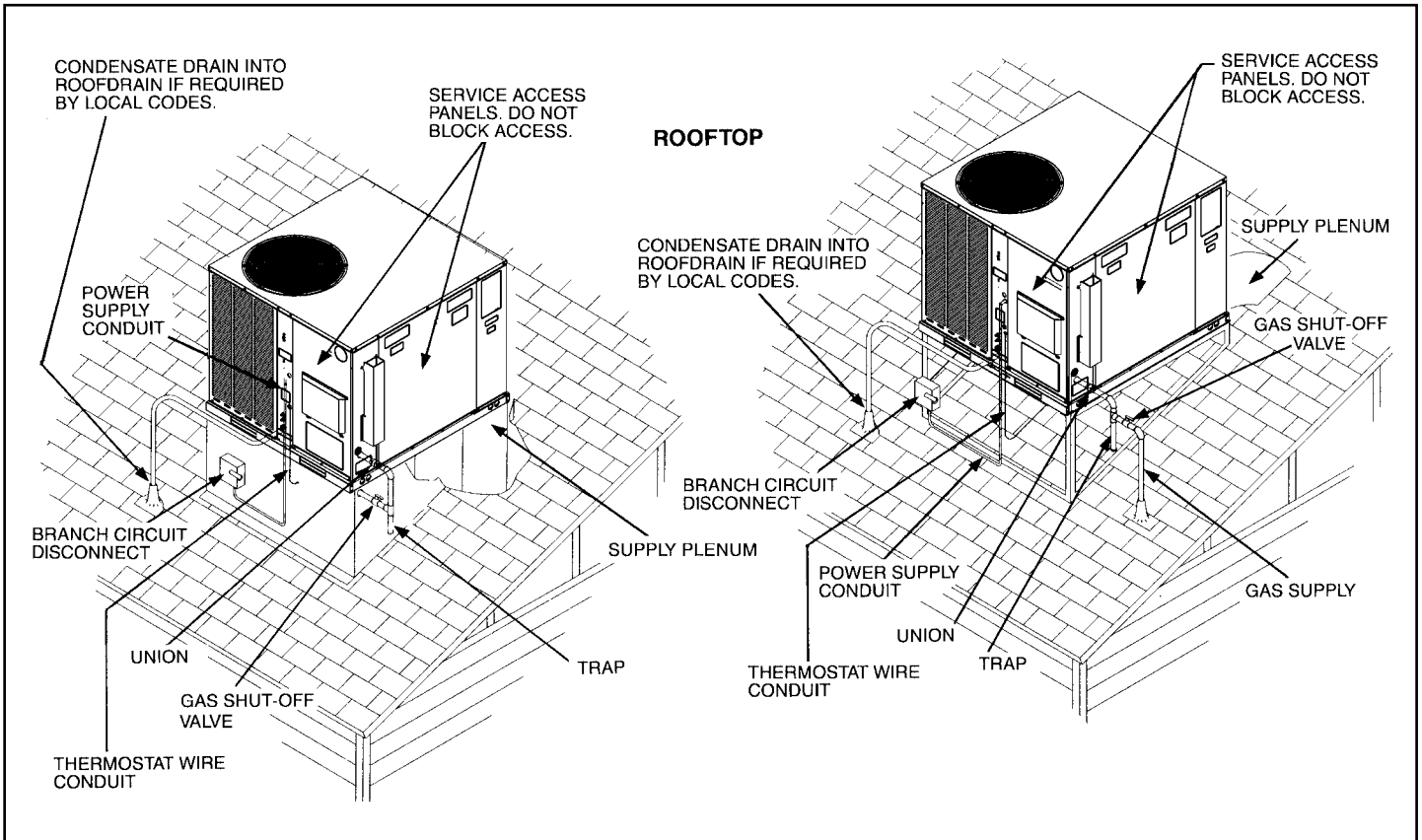

[ ] Designates Metric Conversions

## ACCESSORY EQUIPMENT

Accessory Description	Model Application	Accessory Model No.
Roofcurbs	TZGE-3/TZGE-4	RXSG-AAA08 (8" [203 mm] Height) RXSG-AAA14 (14" [356 mm] Height) RXSG-AAA24 (24" [610 mm] Height)
Supply & Return Diffusers	TZGE-3/TZGE-4	RXRN-BD15
Economizers (Sideflow Only)	TZGE-3/TZGE-4	RXRE-CCA30 (3 Position) RXRD-CCM10 (Fully Modulating)
Economizers (Downflow Only)	TZGE-3/TZGE-4	RXRE-CAA30 (3 Position) RXRD-CAM10 (Fully Modulating)
Fresh Air Damper	TZGE-3/TZGE-4	RXRF-FAB1 (Motorized-35%) RXRF-FAA1 (Fixed-35%)
Rectangular to Round Transition (Downflow)	TZGE-3/TZGE-4	RXMC-CA02 (16" [406 mm] Ducts) RXMC-CA03 (18" [457 mm] Ducts)
Filter Kit	TZGE-3/TZGE-4	RXRY-B01
Sideflow Rectangular to Round Transition	TZGE-3/TZGE-4	RXMC-BA01
LP Conversion Kits	TZGE-3/TZGE-4	RXGJ-EP84W (White-Rodgers Gas Valve) RXGJ-EP85H (Honeywell Gas Valve)
Low Ambient Control	TZGE-3/TZGE-4	RXRZ-B01
High Pressure Control	TZGE-3/TZGE-4 <sup>2</sup>	RXAB-E01
Low Pressure Control	TZGE-3/TZGE-4 <sup>2</sup>	RXAC-C01
Canadian High Altitude Kit (for Natural Gas only <sup>1</sup> )	TZGE-3/TZGE-4	RXRX-AH01

<sup>1</sup> If a particular unit is to be converted to operate on LP (propane) for elevations above 2000 ft. [609.6 m] in Canada, the existing Natural Gas to LP Conversion Kits for the subject models already contain the necessary orifices and instructions to de-rate the input for 2000-4500 ft. [609.6-1371.6 m] Canadian applications.

<sup>2</sup> High and low pressure switches are standard for TZGE-3/TZGE-4 5 Ton models.

[ ] Designates Metric Conversions

## COMMON SUPPLY/RETURN CONCENTRIC AIR DIFFUSER

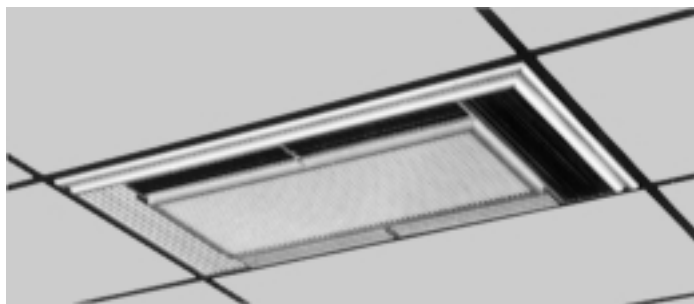

## SUPPLY/RETURN DIFFUSER



Designed to convert a side by side or an over and under arrangement into a concentric distribution of air. The diffuser is flush mounted, completely insulated, assembled, and internally baffled to provide four way supply air distribution with a center return. To make the assembly complete and ready to fit into a 2' [0.61 m] x 4' [1.22 m] suspended ceiling grid, the diffuser includes adjustable supply louvers, hanging rings, anti-sweat gasket, and round flanges for use with flexible ducts.

Model No.	Diameter Inches [mm]	Shipping Wt. Lbs. [kg]	Dimension A Inches [mm]
RXRN-BD15	16 [406]	90 [40.82]	20 1/2 [521]

DIFFUSER INSTALLS FLUSH WITH CEILING

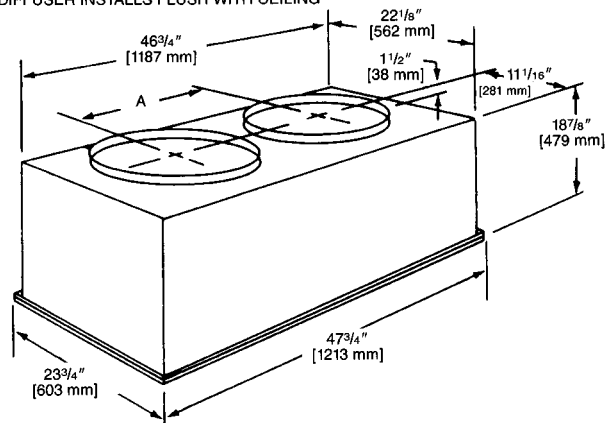

**NOTE:** The location of the combination supply and return diffuser should not exceed 10 feet [3.05 m] above the floor level for units @ 1000 CFM [472 L/s] or less and 12 [3.66 m] to 14 feet [4.27 m] above the floor level for units with CFM greater than 1000 [472 L/s]. If the diffuser is installed with a greater distance than recommended above, the supply air may become stratified above the required comfort area causing uncomfortable conditions.

## AIRFLOW/PRESSURE DROP INFORMATION (INCHES W.C. [kPa])

Accessory	Approximate CFM [L/s]-Supply Air			
	1300 [614]	1575 [743]	1800 [850]	2200 [1038]
Plenum & Supply/Return Duct	.07 [.017]	.10 [.024]	.12 [.030]	.17 [.042]
Diffuser	.09 [.022]	.13 [.032]	.16 [.040]	.24 [.060]
Economizer	.06 [.015]	.09 [.022]	.11 [.027]	.17 [.042]

## SUPPLY AIR/PERFORMANCE

Diffuser Airflow CFM [L/s]	Range of Throw Ft. [m]
800 [378]-1200 [566]	14 [4.27]-16 [4.88]
1600 [755]-2000 [944]	18 [5.49]-28 [8.53]

# ACCESSORIES

## DUCT ADAPTERS RECTANGULAR TO ROUND TRANSITIONS (DOWNFLOW)

RXMC-CA02

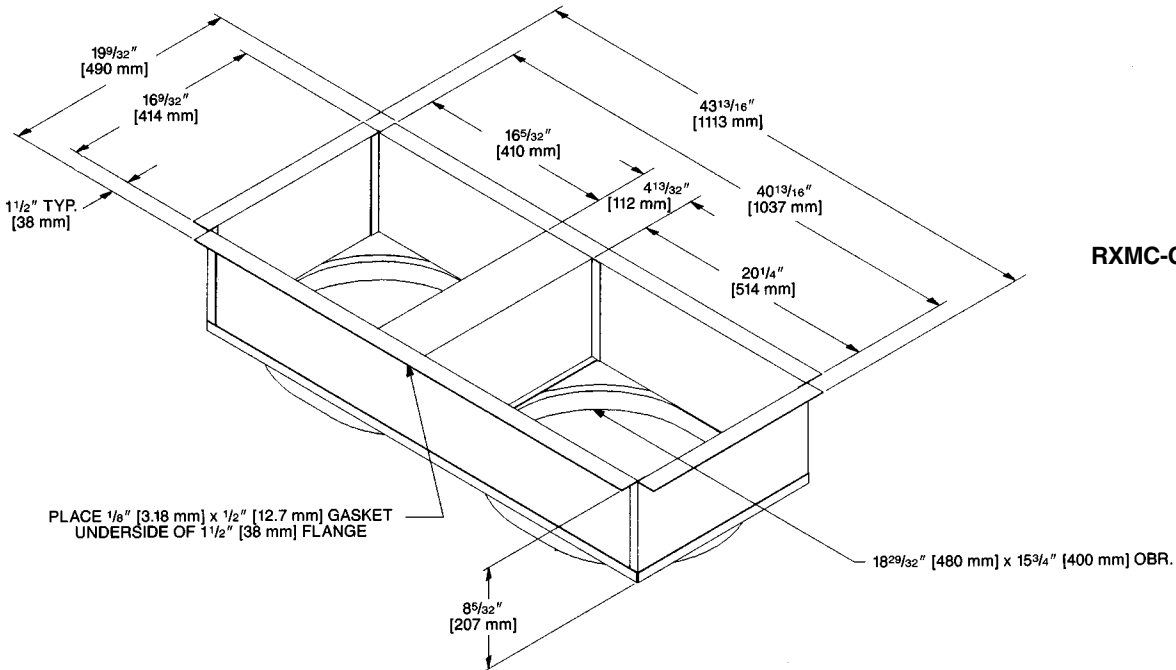
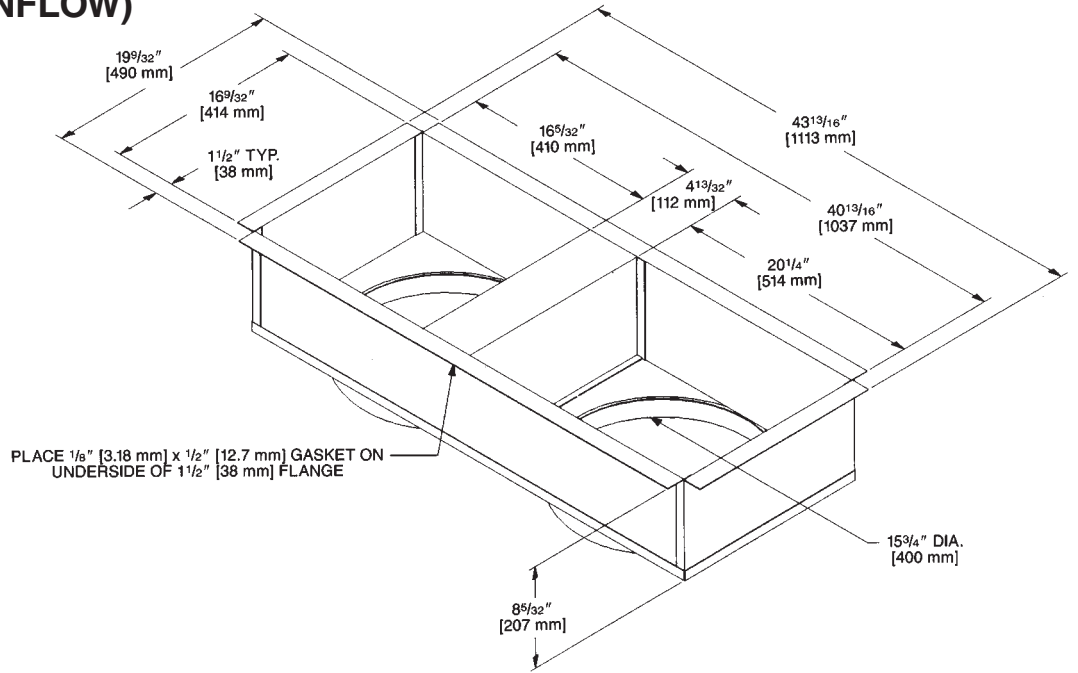

RXMC-CA03

[ ] Designates Metric Conversions



## FRESH AIR DAMPER

### RXRF-FAA1 (Fixed - 0-35%)

The 0-35% manual outside Air Damper is designed to replace the unit return air duct cover. No drilling or damper assembly is required. The amount of outside air (0-35%) is controlled by simply adjusting the side damper.

### RXRF-FAB1 (Motorized - 0-35%)

The 0-35% motorized outside Air Damper is designed to replace the unit return air duct cover. No drilling or damper assembly is required. The control motor opens the adjustable slide damper when the unit blower motor is energized.

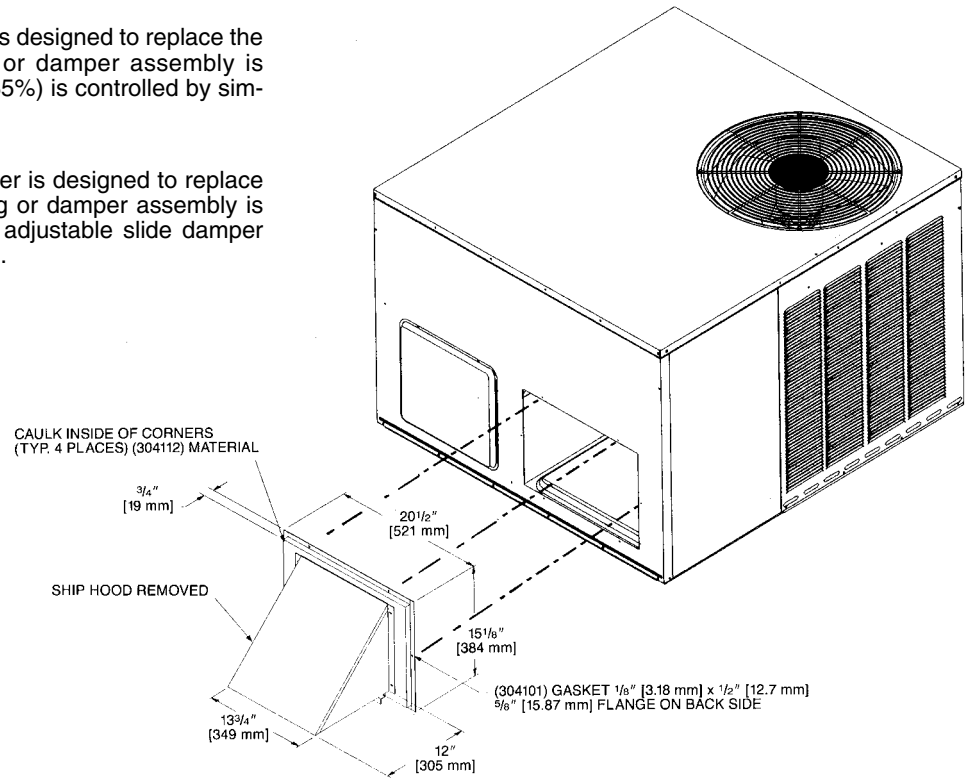

## ECONOMIZERS

### RXRE-CAA30 (3 Position) and RXRD-CAM10 (Fully Modulating)

#### RXRE-CAA30 (3 Position)

Provided with enthalpy control, and mixed air sensor. Settings include fully open, fully closed and adjustable mid point.

#### RXRD-CAM10 (Fully Modulating)

Provided with enthalpy control, mixed air sensor and minimum position potentiometer for proportioning (modulating) the amount of fresh air.

**NOTE:** See economizer installation instructions for correct filter access door.

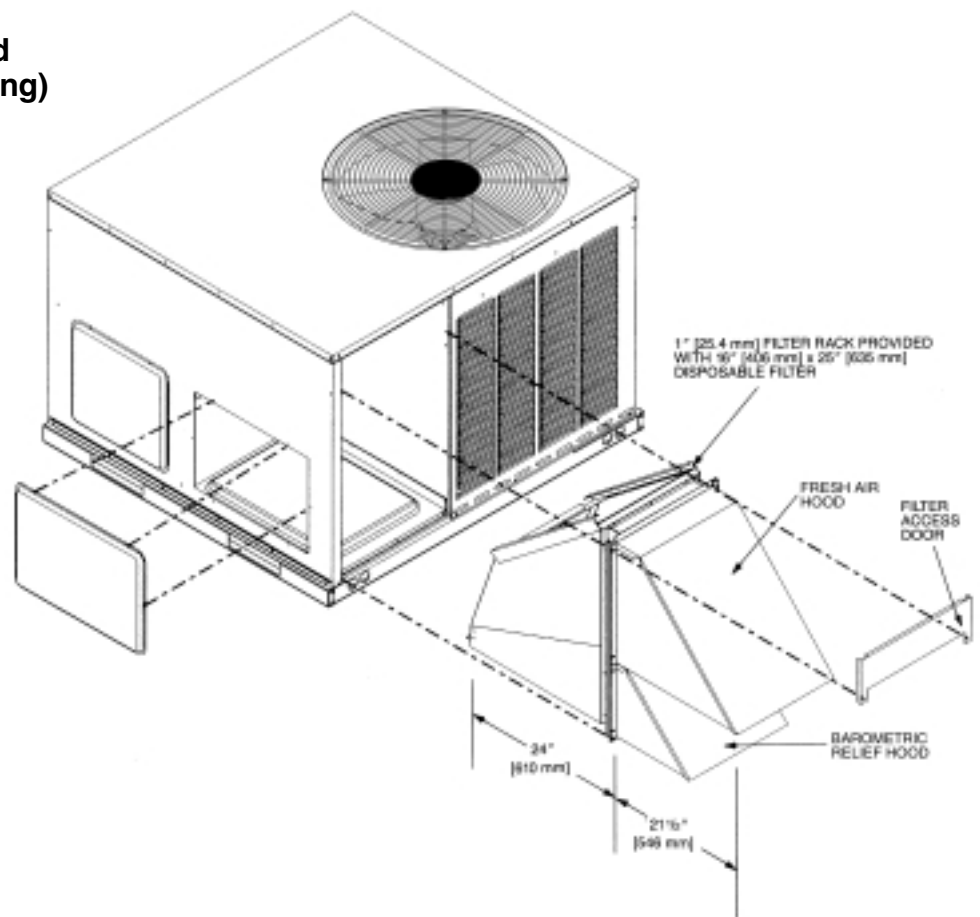

[ ] Designates Metric Conversions

## ECONOMIZERS

### RXRD-CCM10 (Fully Modulating) and RXRE-CCA30 (3 Position) Horizontal Application

#### RXRD-CCM10 (Fully Modulating)

Provided with enthalpy control, mixed air sensor and minimum position potentiometer for proportioning (modulating) the amount of fresh air.

#### RXRE-CCA30 (3-Position)

Has outdoor air sensor, minimum position potentiometer and mixed air sensor to provide three damper positions.

[ ] Designates Metric Conversions

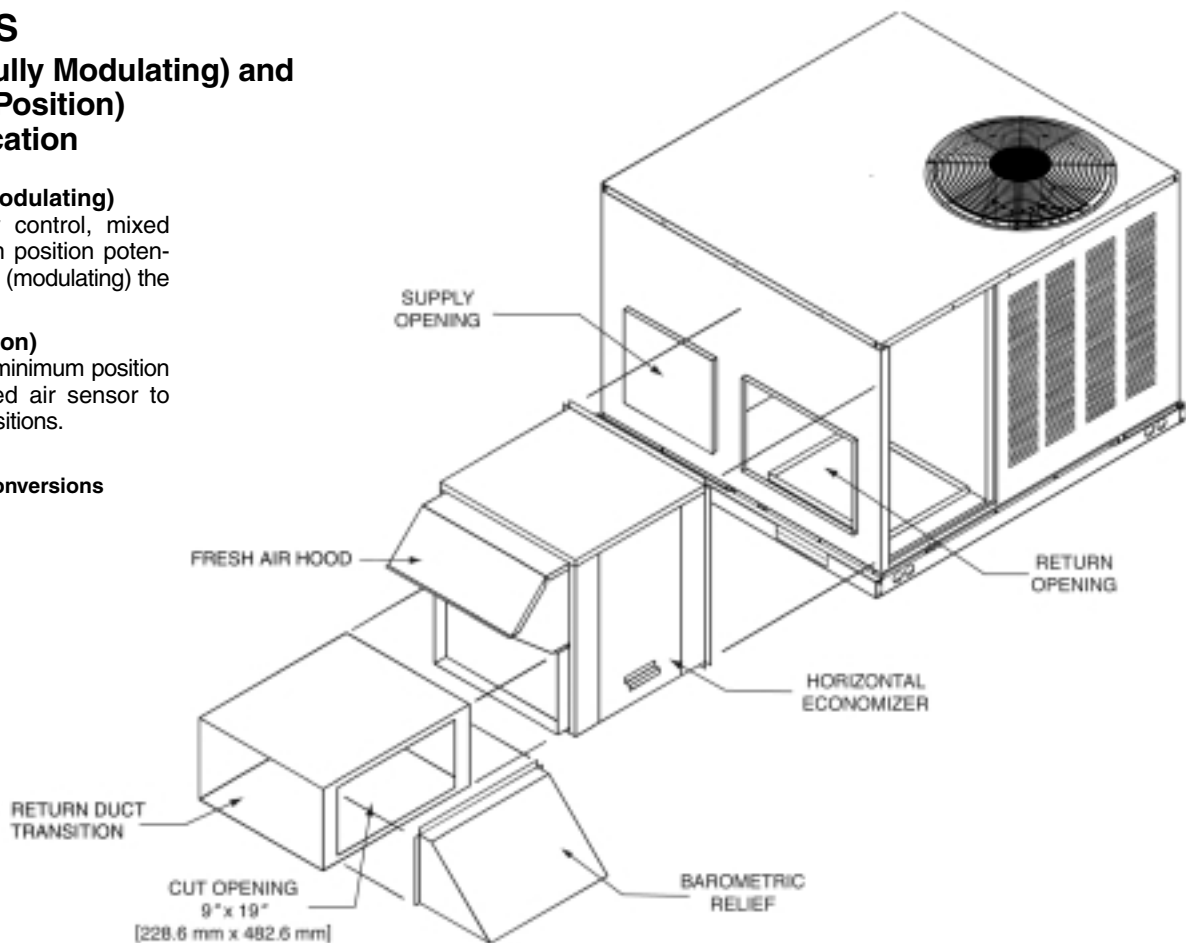

## FILTER KIT INSTALLATION RXRY-B01

For use in either  
vertical or horizontal  
discharge.

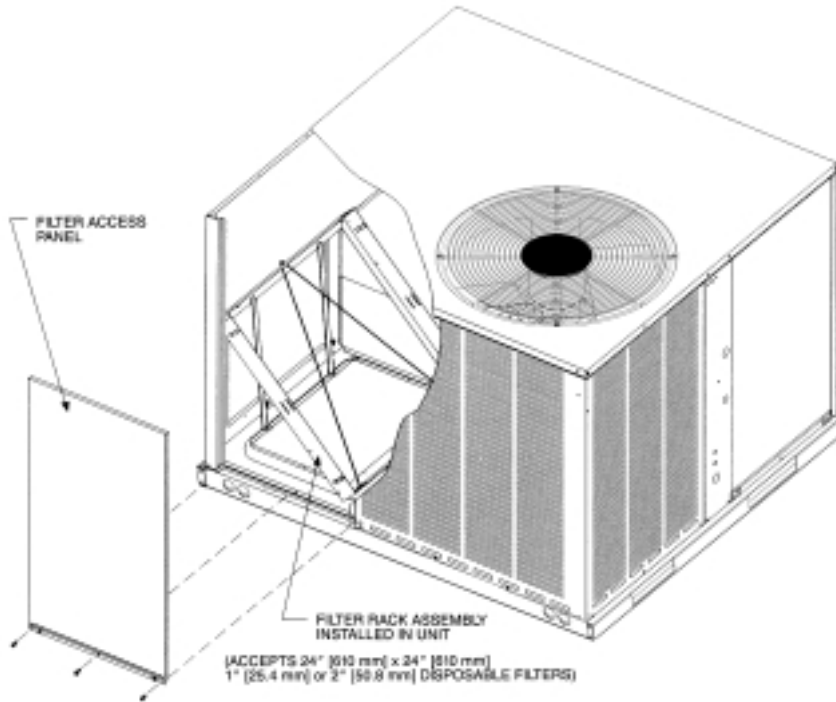

Airflow Pressure Drop, Inches W.C. [kPa]		
CFM [L/s]	1" Filter	2" Filter
500 [236]	.02 [.0050]	.03 [.0075]
600 [283]	.02 [.0050]	.03 [.0075]
700 [330]	.03 [.0075]	.04 [.0101]
800 [378]	.04 [.0101]	.05 [.0124]
900 [425]	.05 [.0124]	.06 [.0149]
1000 [472]	.07 [.0174]	.08 [.0199]
1100 [519]	.08 [.0199]	.09 [.0224]
1200 [566]	.10 [.0249]	.12 [.0299]
1300 [614]	.13 [.0324]	.15 [.0373]
1400 [661]	.16 [.0398]	.19 [.0473]
1500 [708]	.19 [.0473]	.21 [.0523]
1600 [755]	.20 [.0498]	.23 [.0572]
1700 [802]	.21 [.0523]	.24 [.0598]
1800 [850]	.22 [.0548]	.25 [.0623]
1900 [897]	.24 [.0598]	.27 [.0672]
2000 [944]	.26 [.0647]	.29 [.0722]

[ ] Designates Metric Conversions

# ACCESSORIES

## DUCT ADAPTER SIDEFLOW SQUARE TO ROUND TRANSITION RXMC-BA01

Adapts the side rectangular supply and return openings to 14" [356 mm] diameter round openings. Adapters provided with same finish as unit and also provided with thermal insulation.

[ ] Designates Metric Conversions

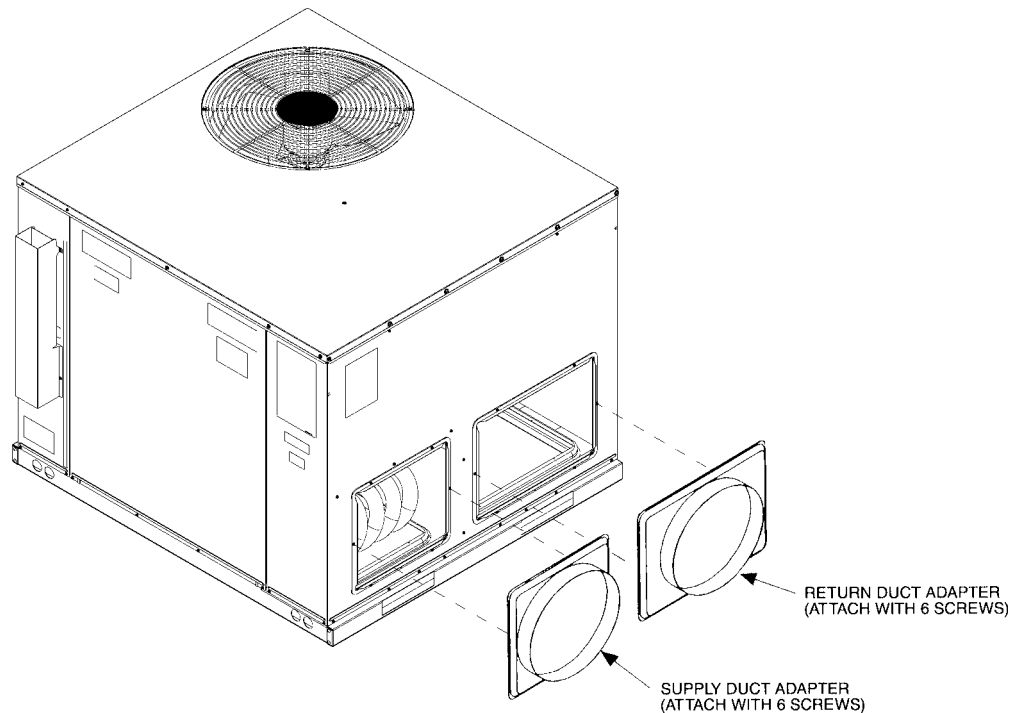

## ROOFCURB (Full Perimeter) RXSG-AAA08, RXSG-AAA14 and RXSG-AAA24

Hinged corners make for fast, easy set-up.

NOT for use with RQKA/RQLA/RQMA Package Heat Pumps.

### RXSG-AAA08 (8" [203 mm] High)

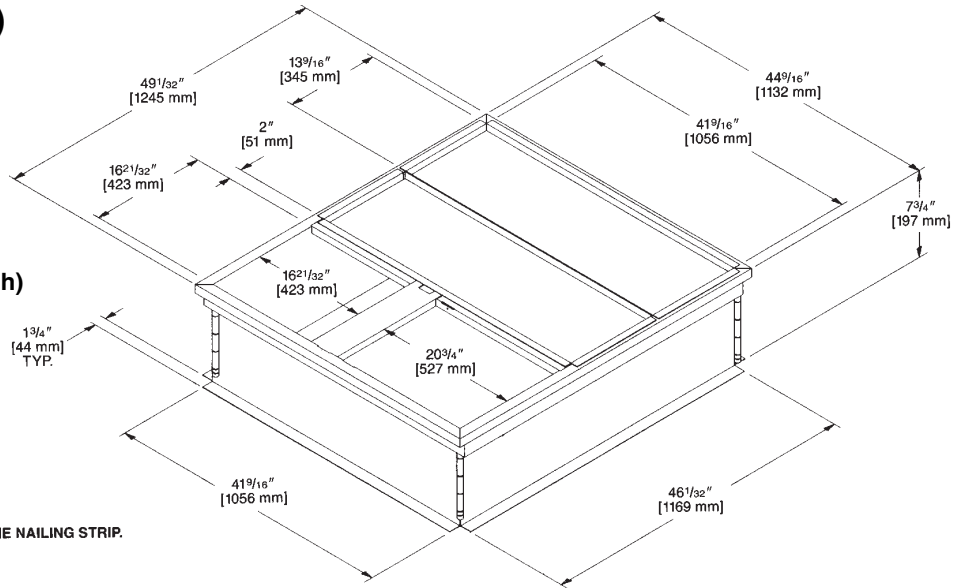

NOTE: PERIMETER OF ROOFCURB IS SUPPLIED WITH A NOMINAL 1" [25.4 mm] x 4" [102 mm] PINE NAILING STRIP.

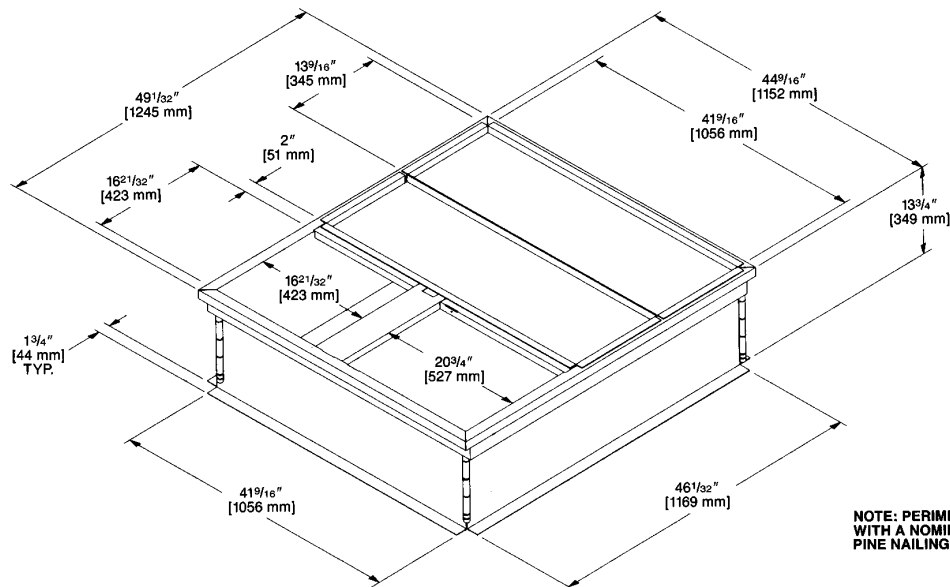

### RXSG-AAA14 (14" [356 mm] High)

NOTE: PERIMETER OF ROOFCURB IS SUPPLIED WITH A NOMINAL 1" [25.4 mm] x 4" [102 mm] PINE NAILING STRIP.

### RXSG-AAA24 (24" [610 mm] High)

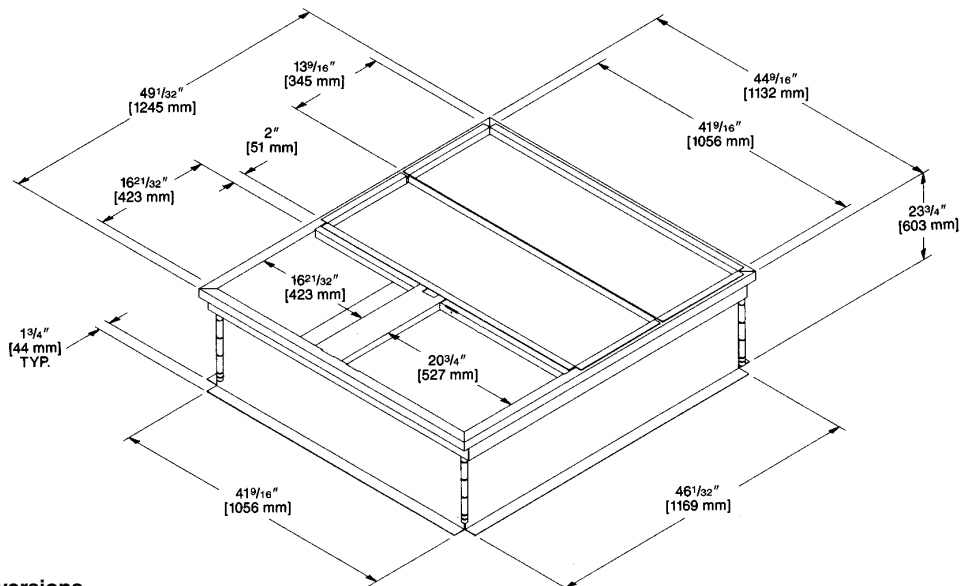

[ ] Designates Metric Conversions

# ACCESSORIES

## PACKAGE AIR CONDITIONERS & PACKAGE GAS/ELECTRIC UNITS ROOFCURB INSTALLATION (Full Perimeter)

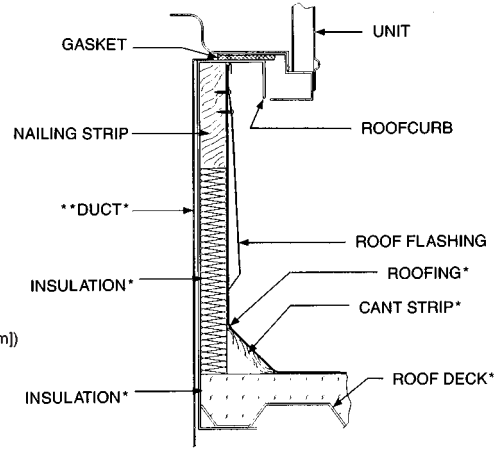
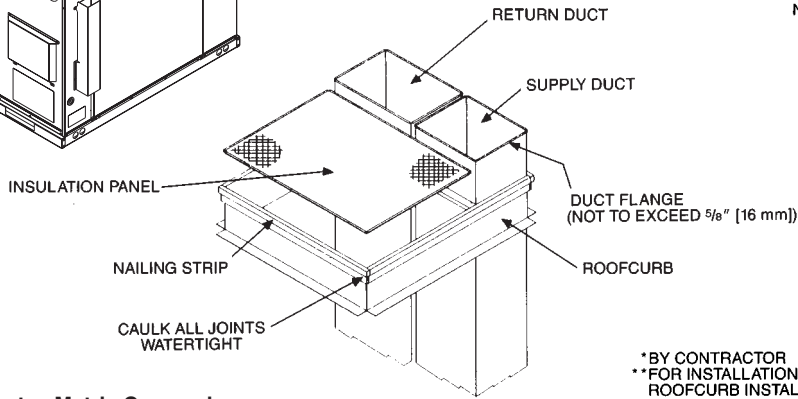
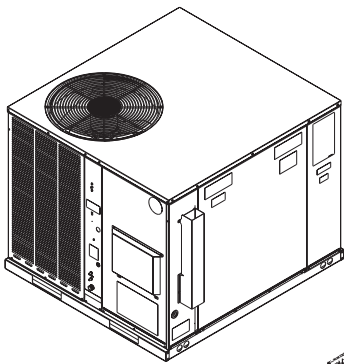

\*BY CONTRACTOR  
\*\*FOR INSTALLATION OF DUCT AS SHOWN, USE RECOMMENDED DUCT SIZES FROM ROOFCURB INSTALLATION INSTRUCTIONS. FOR DUCT FLANGE ATTACHMENT TO UNIT, SEE UNIT INSTALLATION INSTRUCTIONS FOR RECOMMENDED DUCT SIZES.

[ ] Designates Metric Conversions

## ROOFCURB ADAPTERS

Fabricated from galvanized steel to adapt the New cabinet to the old style curb. All are furnished with a New gasket.

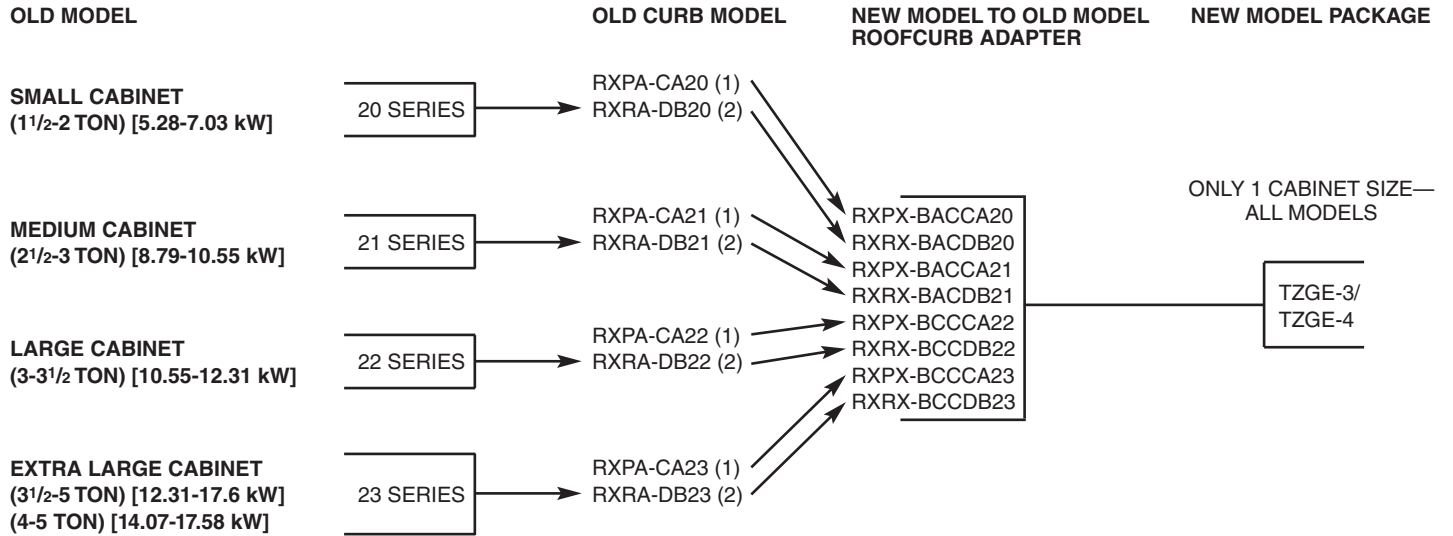

(1) SLOPE TYPE  
(2) FULL PERIMETER TYPE

[ ] Designates Metric Conversions

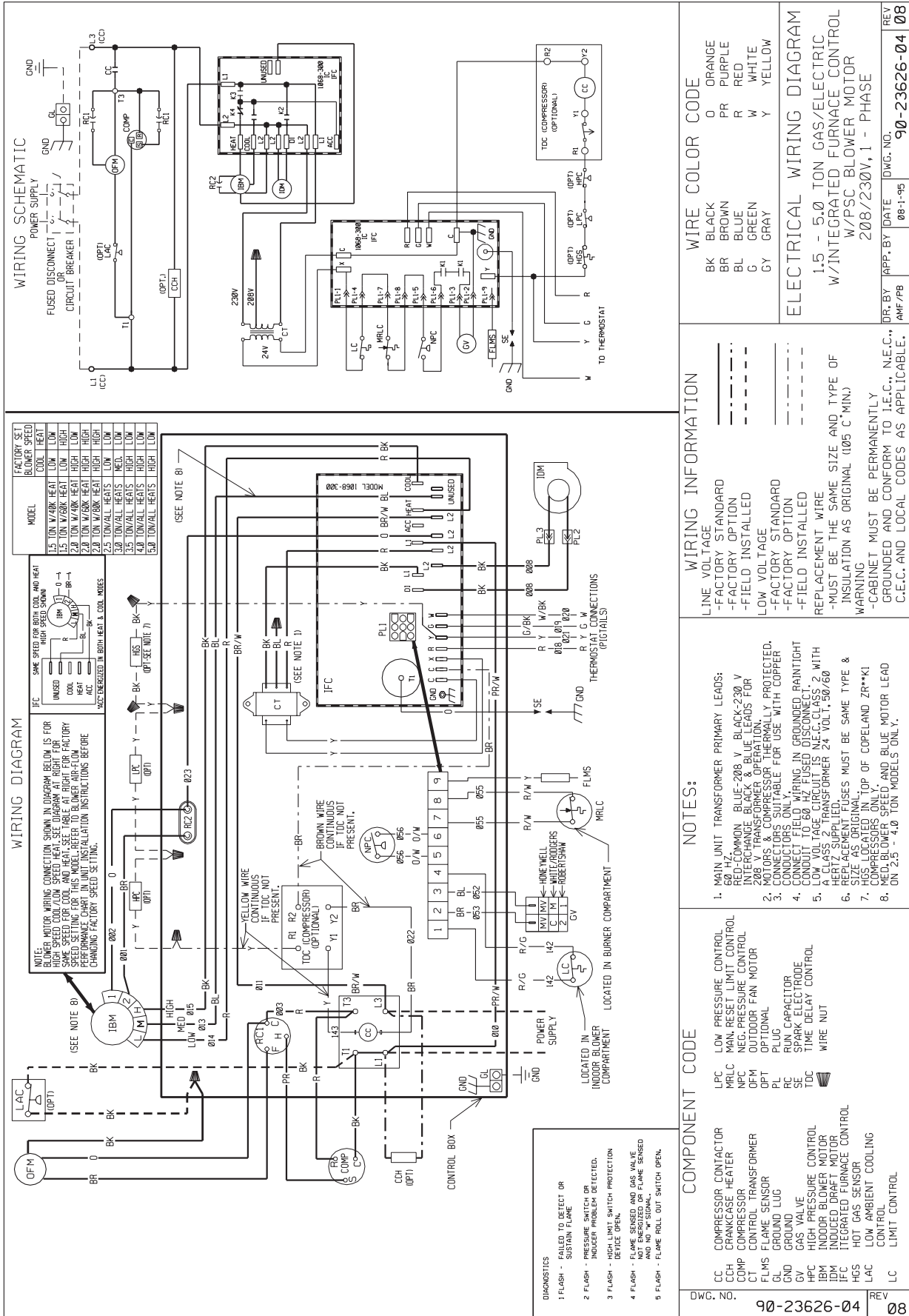







# WIRING SCHEMATICS—TZGE-3/TZGE-4 SERIES

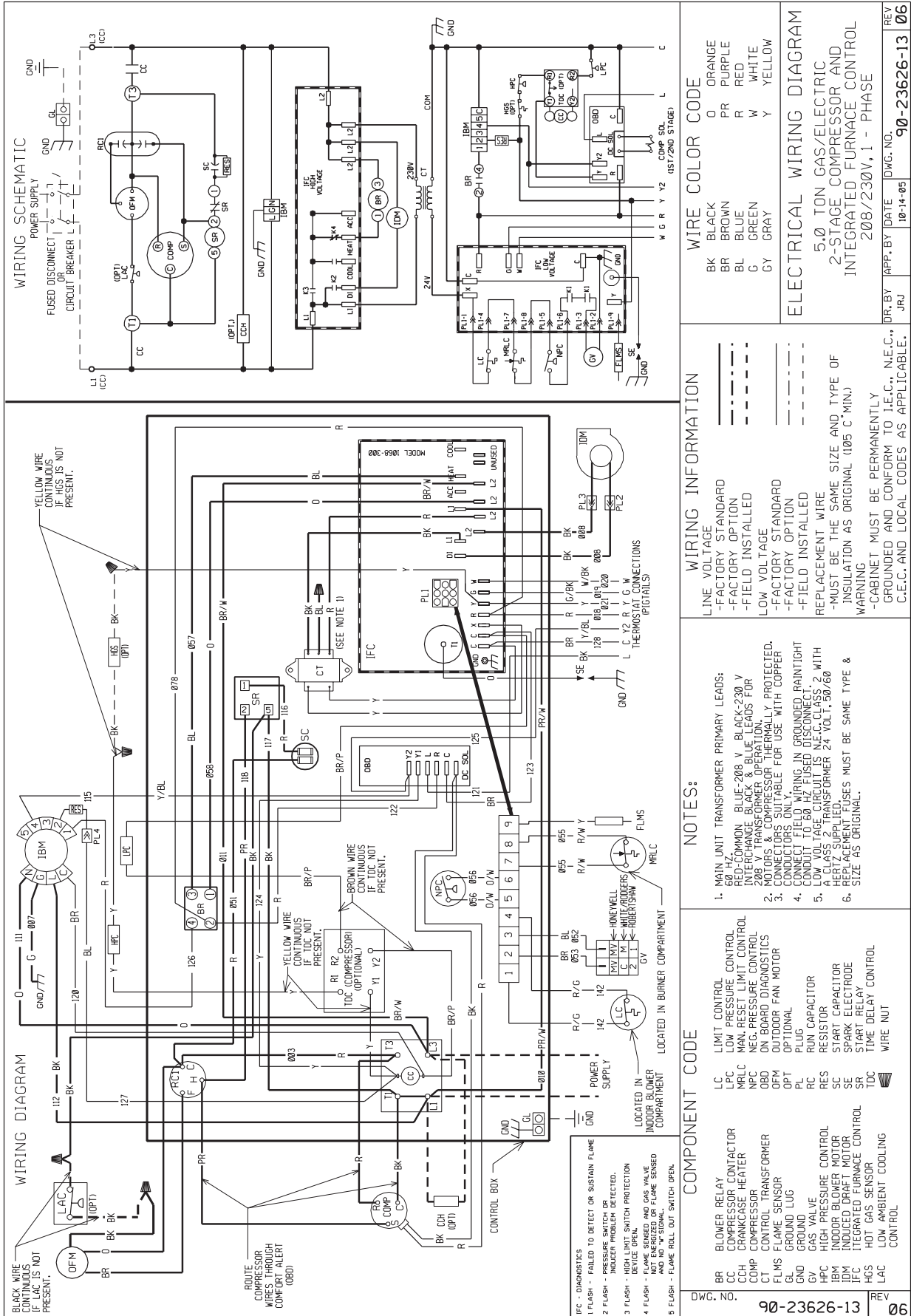

**WIRE COLOR CODE**

BK	BLACK
BR	BROWN
BL	BLUE
C	GREEN
GY	GRAY
O	ORANGE
PR	PURPLE
R	RED
W	WHITE
Y	YELLOW

**ELECTRICAL WIRING DIAGRAM**

5.0 TON GAS/ELECTRIC  
2-STAGE COMPRESSOR AND  
INTEGRATED FURNACE CONTROL  
208/230V, 1 - PHASE

**NOTES:**

1. MAIN UNIT TRANSFORMER PRIMARY LEADS: 60 HZ, RED-COMMON, BLUE-208 V, BLACK-230 V, INTERCHANGE BLACK & BLUE LEADS FOR 208 V TRANSFORMER OPERATION.
2. CONDENSER PUMP MOTOR IS FIELD WIRE PROTECTED.
3. CONDENSER PUMP MOTOR IS FIELD WIRE PROTECTED.
4. CONNECT FIELD WIRING IN GROUNDED RAIN-TIGHT CONDUIT TO 60 HZ FUSED DISCONNECT.
5. LOW VOLTAGE CIRCUIT IS N.E.C. CLASS 2 WITH 150 VOLTAGE RATED.
6. REPLACEMENT FUSES MUST BE SAME TYPE & SIZE AS ORIGINAL.

**COMPONENT CODE**

BR	BLOWER RELAY
CC	COMPRESSOR CONTACTOR
CCH	CRANKCASE HEATER
CCP	COMPRESSOR
CT	CONTROL TRANSFORMER
FLMS	FLAME SENSOR
GL	GROUND LUG
GV	GAS VALVE
HPC	HIGH PRESSURE CONTROL
IBM	INDOOR BLOWER MOTOR
IFC	INTEGRATED DRAFT MOTOR
IFC	INTEGRATED FURNACE CONTROL
SR	START RELAY
TDC	TIME DELAY CONTROL
W	WIRE NUT

**DR. BY** \_\_\_\_\_ **APP. BY** \_\_\_\_\_ **DATE** \_\_\_\_\_ **DWG. NO.** 90-23626-13 **REV** 06



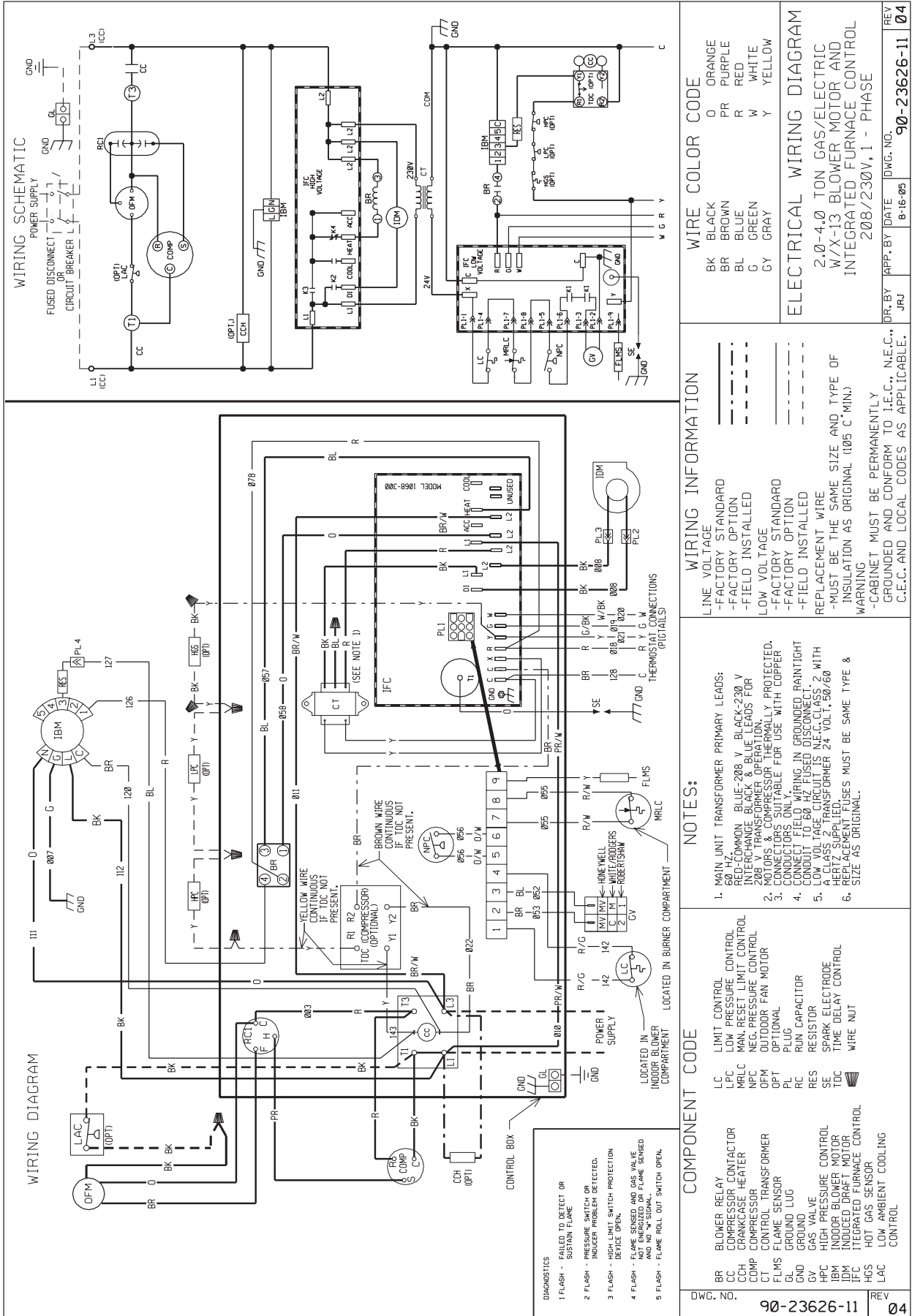

# WIRING SCHEMATICS—TZGE-4 SERIES

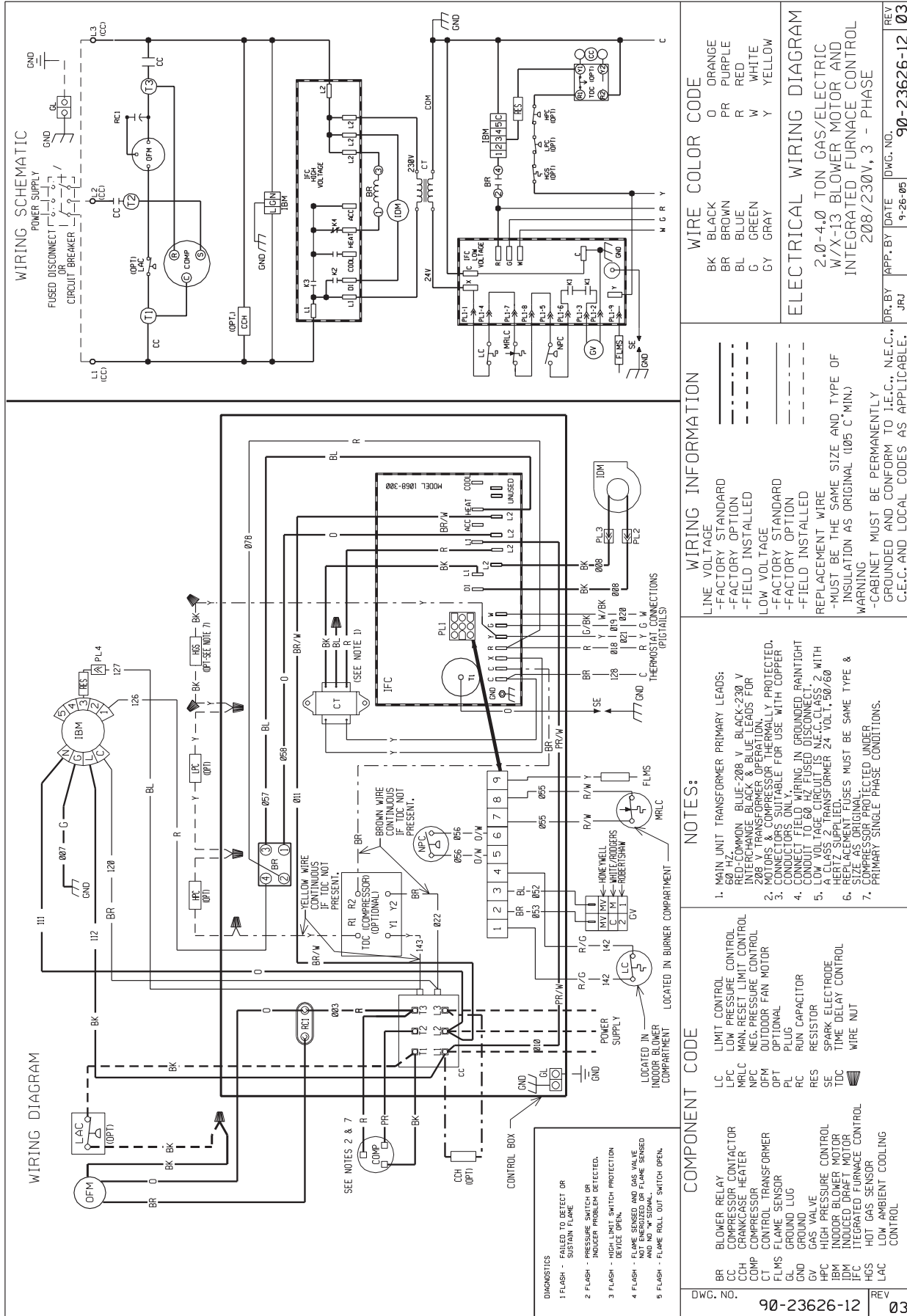









**BEFORE PURCHASING THIS APPLIANCE, READ IMPORTANT ENERGY COST AND EFFICIENCY INFORMATION AVAILABLE FROM YOUR RETAILER.**

### **GENERAL TERMS OF LIMITED WARRANTY**

Thermal Zone® will furnish a replacement for any part of this product which fails in normal use and service within the applicable periods stated, in accordance with the terms of the limited warranty.

#### **Heat Exchanger**

Factory Standard

(13 & 14 SEER Models Only) .....Ten (10) Years

Stainless Steel/1-Phase & 3-Phase Models/

(13 & 14 SEER) Models/

Commercial Application .....Twenty (20) Years

Stainless Steel/1-Phase Models/

Residential Application .....Limited Lifetime

Condenser Coil and Evaporator Coil leaks

caused by factory defects .....Five (5) Years

**For Complete Details of the Limited Warranty, Including Applicable Terms and Conditions, See Your Local Installer or Contact the Manufacturer for a Copy.**

#### **Compressor:**

13 & 14 SEER 1 & 3-Phase Models

(Commercial Applications).....Five (5) Years

13 & 14 SEER 1-Phase Models

(Residential Applications) .....Ten (10) Years

#### **Any Other Part**

13 & 14 SEER 1-Phase Models

(Residential Applications) .....Five (5) Years

13 & 14 SEER 1 & 3-Phase Models

(Commercial Applications) .....One (1) Year

**Before proceeding with installation, refer to installation instructions packaged with each model, as well as complying with all Federal, State, Provincial, and Local codes, regulations, and practices.**

*"In keeping with its policy of continuous progress and product improvement, the right is reserved to make changes without notice."*